



# **Avaya Ethernet Routing Switch 5600 Series Regulatory Information**

6.0  
NN47201-101, 01.03 (324219-A, Rev. 03)  
December 2010

### Notice

While reasonable efforts have been made to ensure that the information in this document is complete and accurate at the time of printing, Avaya assumes no liability for any errors. Avaya reserves the right to make changes and corrections to the information in this document without the obligation to notify any person or organization of such changes.

### Documentation disclaimer

Avaya shall not be responsible for any modifications, additions, or deletions to the original published version of this documentation unless such modifications, additions, or deletions were performed by Avaya. End User agree to indemnify and hold harmless Avaya, Avaya's agents, servants and employees against all claims, lawsuits, demands and judgments arising out of, or in connection with, subsequent modifications, additions or deletions to this documentation, to the extent made by End User.

### Link disclaimer

Avaya is not responsible for the contents or reliability of any linked Web sites referenced within this site or documentation(s) provided by Avaya. Avaya is not responsible for the accuracy of any information, statement or content provided on these sites and does not necessarily endorse the products, services, or information described or offered within them. Avaya does not guarantee that these links will work all the time and has no control over the availability of the linked pages.

### Warranty

Avaya provides a limited warranty on this product. Refer to your sales agreement to establish the terms of the limited warranty. In addition, Avaya's standard warranty language, as well as information regarding support for this product, while under warranty, is available to Avaya customers and other parties through the Avaya Support Web site: <http://www.avaya.com/support>. Please note that if you acquired the product from an authorized Avaya reseller outside of the United States and Canada, the warranty is provided to you by said Avaya reseller and not by Avaya.

### Licenses

THE SOFTWARE LICENSE TERMS AVAILABLE ON THE AVAYA WEBSITE, [HTTP://SUPPORT.AVAYA.COM/LICENSEINFO/](http://SUPPORT.AVAYA.COM/LICENSEINFO/) ARE APPLICABLE TO ANYONE WHO DOWNLOADS, USES AND/OR INSTALLS AVAYA SOFTWARE, PURCHASED FROM AVAYA INC., ANY AVAYA AFFILIATE, OR AN AUTHORIZED AVAYA RESELLER (AS APPLICABLE) UNDER A COMMERCIAL AGREEMENT WITH AVAYA OR AN AUTHORIZED AVAYA RESELLER. UNLESS OTHERWISE AGREED TO BY AVAYA IN WRITING, AVAYA DOES NOT EXTEND THIS LICENSE IF THE SOFTWARE WAS OBTAINED FROM ANYONE OTHER THAN AVAYA, AN AVAYA AFFILIATE OR AN AVAYA AUTHORIZED RESELLER, AND AVAYA RESERVES THE RIGHT TO TAKE LEGAL ACTION AGAINST YOU AND ANYONE ELSE USING OR SELLING THE SOFTWARE WITHOUT A LICENSE. BY INSTALLING, DOWNLOADING OR USING THE SOFTWARE, OR AUTHORIZING OTHERS TO DO SO, YOU, ON BEHALF OF YOURSELF AND THE ENTITY FOR WHOM YOU ARE INSTALLING, DOWNLOADING OR USING THE SOFTWARE (HEREINAFTER REFERRED TO INTERCHANGEABLY AS "YOU" AND "END USER"), AGREE TO THESE TERMS AND CONDITIONS AND CREATE A BINDING CONTRACT BETWEEN YOU AND AVAYA INC. OR THE APPLICABLE AVAYA AFFILIATE ("AVAYA").

### Copyright

Except where expressly stated otherwise, no use should be made of materials on this site, the Documentation(s) and Product(s) provided by Avaya. All content on this site, the documentation(s) and the product(s) provided by Avaya including the selection, arrangement and design of the content is owned either by Avaya or its licensors and is

protected by copyright and other intellectual property laws including the sui generis rights relating to the protection of databases. You may not modify, copy, reproduce, republish, upload, post, transmit or distribute in any way any content, in whole or in part, including any code and software. Unauthorized reproduction, transmission, dissemination, storage, and or use without the express written consent of Avaya can be a criminal, as well as a civil, offense under the applicable law.

### Third-party components

Certain software programs or portions thereof included in the Product may contain software distributed under third party agreements ("Third Party Components"), which may contain terms that expand or limit rights to use certain portions of the Product ("Third Party Terms"). Information regarding distributed Linux OS source code (for those Products that have distributed the Linux OS source code), and identifying the copyright holders of the Third Party Components and the Third Party Terms that apply to them is available on the Avaya Support Web site: <http://www.avaya.com/support/Copyright/>.

### Trademarks

The trademarks, logos and service marks ("Marks") displayed in this site, the documentation(s) and product(s) provided by Avaya are the registered or unregistered Marks of Avaya, its affiliates, or other third parties. Users are not permitted to use such Marks without prior written consent from Avaya or such third party which may own the Mark. Nothing contained in this site, the documentation(s) and product(s) should be construed as granting, by implication, estoppel, or otherwise, any license or right in and to the Marks without the express written permission of Avaya or the applicable third party.

Avaya is a registered trademark of Avaya Inc.

All other trademarks are the property of their respective owners.

### Downloading documents

For the most current versions of documentation, see the Avaya Support Web site: <http://www.avaya.com/support>

### Contact Avaya Support

Avaya provides a telephone number for you to use to report problems or to ask questions about your product. The support telephone number is 1-800-242-2121 in the United States. For additional support telephone numbers, see the Avaya Web site: <http://www.avaya.com/support>

## Contents

<b>Chapter 1: Regulatory information and safety precautions</b>	<b>5</b>
International Regulatory Statements of Conformity	5
National Electromagnetic Compliance (EMC) Statements of Compliance	5
FCC statement (USA only)	5
ICES statement (Canada only)	6
Canadian Department of Communications Radio Interference Regulations	6
Règlement sur le brouillage radioélectrique du ministère des Communications	6
CE marking statement (Europe only)	6
EN 55022 statements	6
EN 55024 statement	7
EN 300386 statement	7
European Union and European Free Trade Association (EFTA) notice	7
VCCI statement (Japan/Nippon only)	7
BSMI statement (Taiwan only)	8
MIC notice (Republic of Korea only)	8
National Safety Statements of Compliance	8
EN 60950 statement	8
NOM statement (Mexico only)	9
Información NOM (unicamente para México)	9
Denan statement (Japan/Nippon only)	10
National Environmental Statement of Compliance	11
Restriction on Hazardous Substances Directive Compliance Statement	11
WEEE Directive Compliance Statement	11
How To Get Help	12
Getting technical documentation	12
Getting product training	12
Getting help from a distributor or reseller	12
Getting technical support from the Avaya Web site	12
Getting technical support from the Avaya Web site	13
Notices	13
Avaya Ethernet Routing Switch 5600 Series	14
<b>Chapter 2: English</b>	<b>15</b>
Before you begin	15
Installing the switch on a table or shelf	15
Installing the switch in an equipment rack	17
AC and DC power specifications	21
Connecting AC power	23
Safety messages	25
<b>Chapter 3: Deutsche</b>	<b>27</b>
Hinweise zur Verwendung	27
Installation des Switch auf einem Tisch oder Regal	27
Installation des Switch in einem Rack	29
Leistungsdaten	34
Leistungsdaten (Wechselstrom und DC)	34
Wechselstrom-Anschluss	36
Sicherheitsinformationen	38

<b>Chapter 4: Español</b> .....	<b>41</b>
Antes de comenzar.....	41
Instalación del conmutador en una mesa o estantería.....	41
Instalación del conmutador en un bastidor para equipos.....	43
Especificaciones eléctricas.....	48
Especificaciones de la potencia cc de la CA y.....	48
Conexión a CA.....	50
Mensajes de seguridad.....	52
<b>Chapter 5: Français</b> .....	<b>55</b>
Avant de commencer.....	55
Installation du commutateur sur une table ou sur une étagère.....	55
Installation du commutateur dans un rack.....	57
Alimentation: Caractéristiques.....	62
Alimentation secteur: caractéristiques.....	62
Alimentation secteur: connexion.....	64
Messages de sécurité.....	66
<b>Chapter 6: Português</b> .....	<b>69</b>
Antes de você comece.....	69
Instalando o ERS 5600 Series em uma tabela ou em uma prateleira.....	69
Instalando o ERS 5600 Series em uma cremalheira de equipamento.....	71
Especificações do poder.....	76
Especificações da alimentação de DC da C. A. e.....	76
Poder de C.A. conectando.....	78
Mensagens de segurança.....	80

# Chapter 1: Regulatory information and safety precautions

Read the information in this section to learn about regulatory conformities and compliance.

---

## International Regulatory Statements of Conformity

This is to certify that the Ethernet Routing Switch 5600 Series equipment was evaluated to the international regulatory standards for electromagnetic compliance (EMC) and safety and were found to have met the requirements for the following international standards:

- EMC – Electromagnetic Emissions – CISPR 22, Class A
- EMC – Electromagnetic Immunity – CISPR 24
- Electrical Safety – IEC 60950, with CB member national deviations

Further, the equipment has been certified as compliant with the national standards as detailed below.

---

## National Electromagnetic Compliance (EMC) Statements of Compliance

---

### FCC statement (USA only)

This equipment has been tested and found to comply with the limits for a Class A digital device, pursuant to Part 15 of the Federal Communications Commission (FCC) rules. These limits are designed to provide reasonable protection against harmful interference when the equipment is operated in a commercial environment. This equipment generates, uses, and can radiate radio frequency energy. If it is not installed and used in accordance with the instruction manual, it may cause harmful interference to radio communications. Operation of this equipment in a residential area is likely to cause harmful interference, in which case users will be required to take whatever measures may be necessary to correct the interference at their own expense.

---

## **ICES statement (Canada only)**

---

### **Canadian Department of Communications Radio Interference Regulations**

This digital apparatus (Ethernet Routing Switch 5600 Series) does not exceed the Class A limits for radio-noise emissions from digital apparatus as set out in the Radio Interference Regulations of the Canadian Department of Communications.

---

### **Règlement sur le brouillage radioélectrique du ministère des Communications**

Cet appareil numérique (le commutateur ERS 5600 Series) respecte les limites de bruits radioélectriques visant les appareils numériques de classe A prescrites dans le Règlement sur le brouillage radioélectrique du ministère des Communications du Canada.

---

## **CE marking statement (Europe only)**

---

### **EN 55022 statements**

This is to certify that the Ethernet Routing Switch 5600 Series equipment is shielded against the generation of radio interference in accordance with the application of Council Directive 2004/108/EC. Conformity is declared by the application of EN 55022 Class A (CISPR 22).

---

## EN 55024 statement

This is to certify that the Ethernet Routing Switch 5600 Series are shielded against the susceptibility to radio interference in accordance with the application of Council Directive 2004/108/EC. Conformity is declared by the application of EN 55024 (CISPR 24).


---

## EN 300386 statement

The Ethernet Routing Switch 5600 Series complies with the requirements of EN 300386 V1.3.3 for emissions and for immunity for a Class A device intended for use in either Telecommunications centre or locations other than telecommunications centres given the performance criteria as specified by the manufacturer.

---

## European Union and European Free Trade Association (EFTA) notice

 All products labeled with the CE marking comply with R&TTE Directive (1999/5/EEC) which includes the Electromagnetic Compliance (EMC) Directive (2004/108/EC) and the Low Voltage Directive (2006/95/EC) issued by the Commission of the European Community.

Compliance with these directives implies conformity to the following European Norms (ENs). The equivalent international standards are listed in parenthesis.

- EN 55022 (CISPR 22)–Electromagnetic Interference
- EN 55024 (IEC 61000-4-2, -3, -4, -5, -6, -8, -11)–Electromagnetic Immunity
- EN 61000-3-2 (IEC 61000-3-2)–Power Line Harmonics
- EN 61000-3-3 (IEC 61000-3-3)–Power Line Flicker

---

## VCCI statement (Japan/Nippon only)

This is a Class A product based on the standard of the Voluntary Control Council for Interference (VCCI) for information technology equipment. If this equipment is used in a

domestic environment, radio disturbance may arise. When such trouble occurs, the user may be required to take corrective actions.

この装置は、情報処理装置等電波障害自主規制協議会（VCCI）の基準に基づくクラスA情報技術装置です。この装置を家庭環境で使用すると電波妨害を引き起こすことがあります。この場合には使用者が適切な対策を講ずるよう要求されることがあります。

---

## BSMI statement (Taiwan only)

This is a Class A product based on the standard of the Bureau of Standards, Metrology and Inspection (BSMI) CNS 13438 and CNS14336 , Class A.

警告使用者：

這是甲類的資訊產品，在居住的環境中使用時，可能會造成射頻干擾，在這種情況下，使用者會被要求採取某些適當的對策。

---

## MIC notice (Republic of Korea only)

This device has been approved for use in Business applications only per the Class A requirements of the Republic of Korea Ministry of Information and Communications (MIC). This device may not be sold for use in a non-business application.

Observe the Regulatory Marking label on the back or bottom of each switch for specific certification information pertaining to this model. Each Ethernet Routing Switch 5600 Series model is approved for shipment to/usage in Korea and is labeled as such, with all appropriate text and the appropriate MIC reference number.

---

## National Safety Statements of Compliance

---

### EN 60950 statement

This is to certify that the Ethernet Routing Switch 5600 Series equipment is in compliance with the requirements of EN 60950 in accordance with the Low Voltage Directive. Additional national differences for all European Union countries have been evaluated for compliance.



---

## NOM statement (Mexico only)

The following information is provided on the devices described in this document in compliance with the safety requirements of the Norma Oficial Mexicana (NOM):

Exporter: Avaya Inc., 4655 Great America Parkway, Santa Clara, CA 95054 USA.

Importer: Avaya Communication de México S.A. de C.V.  
Av. Presidente Masarik 111  
Piso 6, Col Chapultepec Morales  
Deleg. Miguel Hidalgo  
México D.F. 11570

Input: Ethernet Routing Switch 5600 Series:

- 5632FD  
AC 100-240 V~ 5A 47-63 Hz  
DC 48 VDC 10A  
Chassis power consumption: 300 Watts MAX
- 5650TD  
AC 100-240 V~ 5A 47-63 Hz per power supply  
DC 48 VDC 10A  
Chassis power consumption: 300 Watts MAX
- 5650TD-PWR  
AC 100-240 V~ 8A 47-63 Hz per power supply  
AC 100-240 V~12A 47-63 Hz per power supply  
DC 48 VDC 35A  
Chassis power consumption: 1000 Watts MAX
- 5698TFD  
AC 100-240 V~ 5A 47-63 Hz per power supply  
DC 48 VDC 10A  
Chassis power consumption: 300 Watts MAX
- 5698TFD-PWR  
AC 100-240 V~ 8A 47-63 Hz per power supply  
AC 200-240 V~12A 47-63 Hz per power supply  
DC 48V 35A per power supply  
Chassis power consumption: 2000 Watts MAX from 2 power supplies

---

## Información NOM (unicamente para México)

La información siguiente se proporciona en el dispositivo o en los dispositivos descritos en este documento, en cumplimiento con los requisitos de la Norma Oficial Mexicana (NOM):

## Regulatory information and safety precautions

Exportador: Avaya Inc., 4655 Great America Parkway, Santa Clara, CA 95054 USA.

Importador: Avaya Communication de México S.A. de C.V.  
Av. Presidente Masarik 111 Piso 6,  
Col Chapultepec Morales  
Deleg. Miguel Hidalgo  
México D.F. 11570

Embarcar a: Ethernet Routing Switch 5600 Series

- 5632FD  
AC 100-240 V~ 5A 47-63 Hz  
DC 48 VDC 10A  
Consumo de energía del chasis: 300 Vatios De MÁXIMO
- 5650TD  
AC 100-240 V~ 5A 47-63 Hz per power supply  
DC 48 VDC 10A  
Consumo de energía del chasis: 300 Vatios De MÁXIMO
- 5650TD-PWR  
AC 100-240 V~ 8A 47-63 Hz per power supply  
AC 100-240 V~12A 47-63 Hz per power supply  
DC 48 VDC 35A  
Consumo de energía del chasis: 1000 Vatios De MÁXIMO
- 5698TFD  
AC 100-240 V~ 5A 47-63 Hz per power supply  
DC 48 VDC 10A  
Consumo de energía del chasis: 300 Vatios De MÁXIMO
- 5698TFD-PWR  
AC 100-240 V~ 8A 47-63 Hz per power supply  
AC 200-240 V~12A 47-63 Hz per power supply  
DC 48VDC 35A per power supply  
Consumo de energía del chasis: 2000 vatios de MÁXIMO a partir de 2 fuentes de alimentación

---

## Denan statement (Japan/Nippon only)

本製品を安全にご使用頂くため、以下のことにご注意ください。

- 接続ケーブル、電源コード、ACアダプタなどの部品は、必ず製品に同梱されております添付品または指定品をご使用ください。添付品・指定品以外の部品をご使用になると故障や動作不良、火災の原因となることがあります。
- 同梱されております付属の電源コードを他の機器には使用しないでください。上記注意事項を守らないと、死亡や大怪我など人身事故の原因となることがあります。

---

## National Environmental Statement of Compliance

The WEEE Directive 2002/96/EC and RoHS (Restriction of Hazardous Substances) Directive 2002/95/EC sets collection, recycling and recovery targets for various categories of electrical products and their waste.

---

## Restriction on Hazardous Substances Directive Compliance Statement

The Restriction on Hazardous Substances Directive (RoHS) (2002/95/EC), which accompanies the WEEE Directive, bans the use of heavy metals and brominated flame-retardants in the manufacture of electrical and electronic equipment. Specifically, restricted materials under the RoHS Directive are Lead (including solder used in PCB's), Cadmium, Mercury, Hexavalent Chromium, and Bromine.

Avaya declares compliance with the European Union (EU) RoHS Directive (2002/95/EC) in that Lead, which is a restricted hazardous substance, is used only in accordance to the exemption(s) to Article 4(1), item 7 granted by the European Union (EU) RoHS Directive (2002/95/EC) in the Annex—"lead in solders for network infrastructure equipment for switching, signalling, transmission as well as network management for telecommunication".

---

## WEEE Directive Compliance Statement



This product at end of life is subject to separate collection and treatment in the EU Member States, Norway, and Switzerland and therefore is marked with the symbol shown at the left. Treatment applied at end of life of these products in these countries shall comply with the applicable national laws implementing Directive 2002/96/EC on Waste of Electrical and Electronic Equipment (WEEE).

Avaya declares compliance with the European Union (EU) WEEE Directive (2002/96/EC).

## How To Get Help

Visit the Avaya Web site to access the complete range of services and support that Avaya provides. Go to [www.avaya.com](http://www.avaya.com) or go to one of the pages listed in the following sections.

### Navigation

- [Getting technical documentation](#) on page 12
- [Getting product training](#) on page 12
- [Getting help from a distributor or reseller](#) on page 12
- [Getting technical support from the Avaya Web site](#) on page 13

---

## Getting technical documentation

To download and print selected technical publications and release notes directly from the Internet, go to [www.avaya.com/support](http://www.avaya.com/support).

---

## Getting product training

Ongoing product training is available. For more information or to register, you can access the Web site at [www.avaya.com/support](http://www.avaya.com/support). From this Web site, you can locate the Training contacts link on the left-hand navigation pane.

---

## Getting help from a distributor or reseller

If you purchased a service contract for your Avaya product from a distributor or authorized reseller, contact the technical support staff for that distributor or reseller for assistance.

---

## Getting technical support from the Avaya Web site

The easiest and most effective way to get technical support for Avaya products is from the Avaya Technical Support Web site at [www.avaya.com/support](http://www.avaya.com/support).

---

## Getting technical support from the Avaya Web site

The easiest and most effective way to get technical support for Avaya products is from the Avaya Technical Support Web site at [www.avaya.com/support](http://www.avaya.com/support).

---

### Notices

Notice paragraphs alert you about issues that require your attention. The following paragraphs describe the types of notices used in this guide.

 **Note:**

Notes provide tips and useful information regarding the installation and operation of Avaya products.

 **Electrostatic alert:**  
**ESD**

ESD notices provide information about how to avoid discharge of static electricity and subsequent damage to Avaya products.

 **Caution:**

Caution notices provide information about how to avoid possible service disruption or damage to Avaya products.

 **Warning:**

Warning notices provide information about how to avoid personal injury when working with Avaya products.

 **Voltage:**

Danger — High Voltage notices provide information about how to avoid a situation or condition that can cause serious personal injury or death from high voltage or electric shock.

 **Danger:**

Danger notices provide information about how to avoid a situation or condition that can cause serious personal injury or death.

---

## **Avaya Ethernet Routing Switch 5600 Series**

The information presented in this document applies to the following products:

- Avaya Ethernet Routing Switch 5632FD
- Avaya Ethernet Routing Switch 5650TD
- Avaya Ethernet Routing Switch 5650TD-PWR
- Avaya Ethernet Routing Switch 5698TFD
- Avaya Ethernet Routing Switch 5698TFD-PWR

# Chapter 2: English

---

## Before you begin

Ensure the area where you install and use the Avaya ERS 5600 Series switch meets the following environmental requirements:

- Ambient temperature between 32° and 106° F (0° and 50° C)
- Relative humidity between 10% and 90% noncondensing
- No nearby heat sources such as hot air vents or direct sunlight
- No nearby sources of severe electromagnetic noise
- No excessive dust
- Adequate power source within six feet; one circuit required for each power supply (see table, AC and DC power specifications)
- At least 2 inches (5.08 cm) on each side of the switch unit for ventilation
- Adequate space at the front and rear of the switch for access to cables

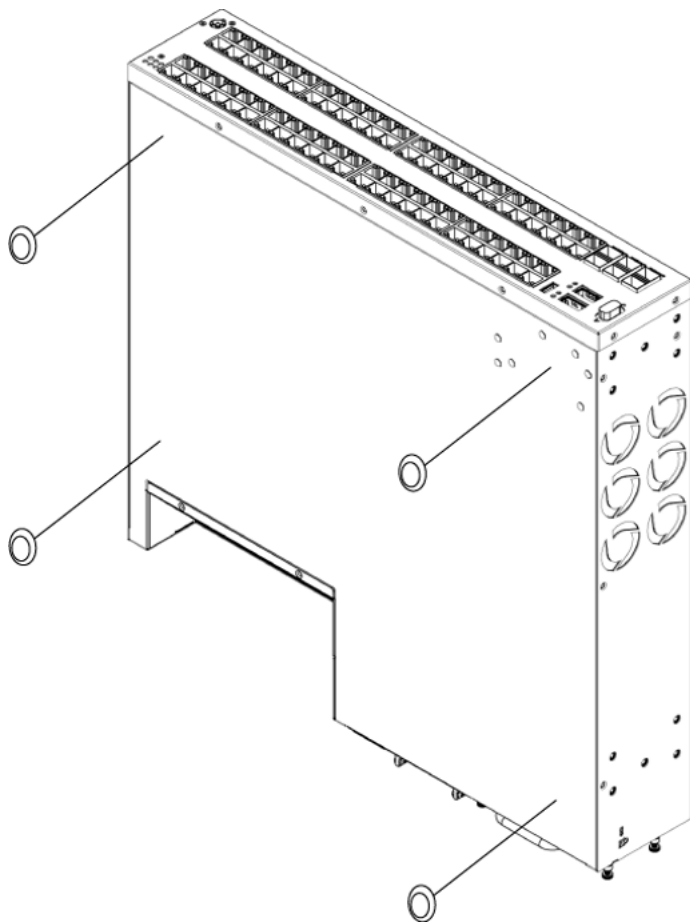
If you are installing a single Avaya Ethernet Routing Switch on a table or shelf, ensure the surface can support at least 21 to 33 pounds (9.5 to 15 kilograms).

---

## Installing the switch on a table or shelf

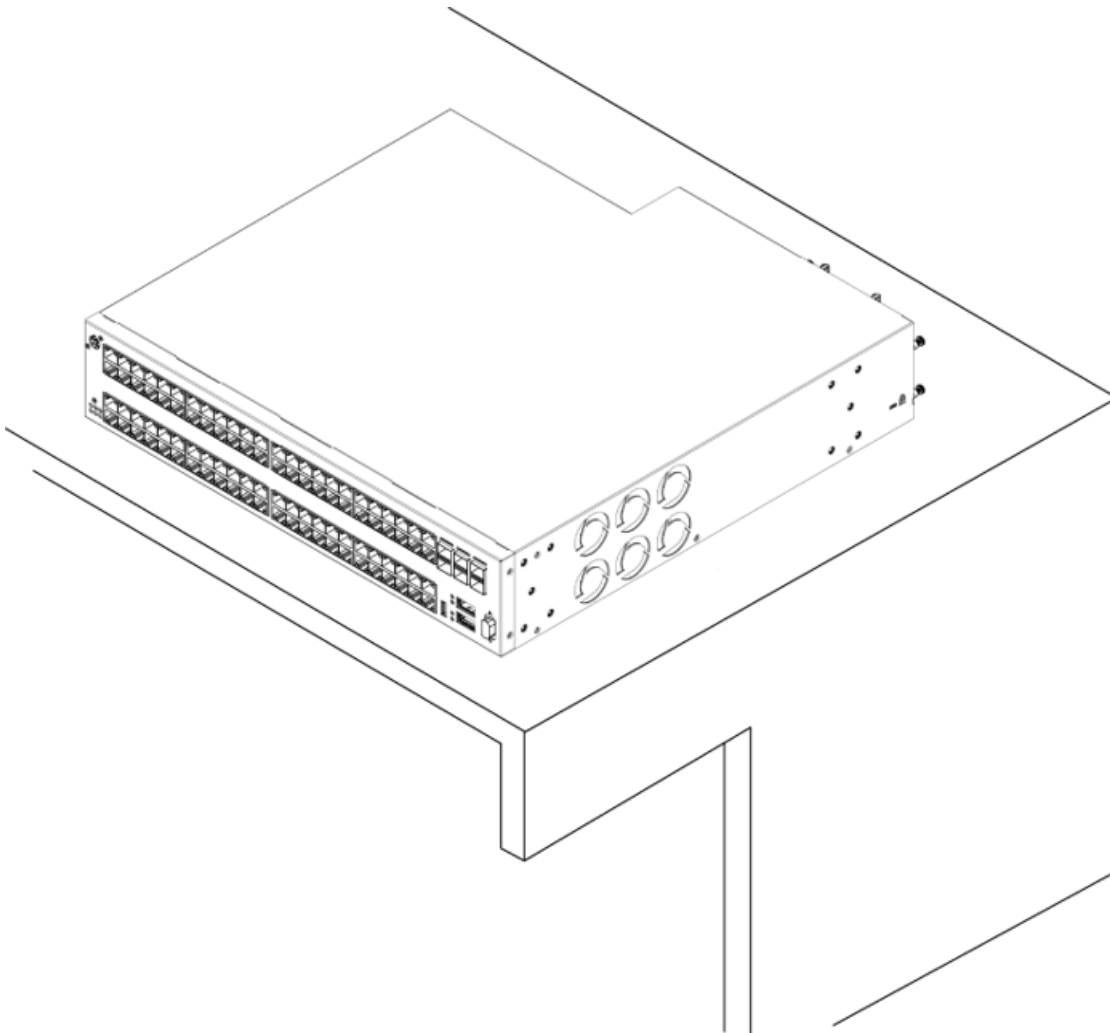
You can install a single Avaya Ethernet Routing Switch on any flat surface that can safely support the weight of the switch and attached cables (21 to 33 pounds or 9.5 to 15 kilograms).

The following figures provide instructions for installing the switch on a table or shelf.



Attach the rubber feet at the marked locations.





Set the switch on a table or shelf.

**\* Note:**

Allow at least 2 inches (5.1 cm) on each side for proper ventilation and at least 5 inches (12.7 cm) at the back for power cord clearance.

---

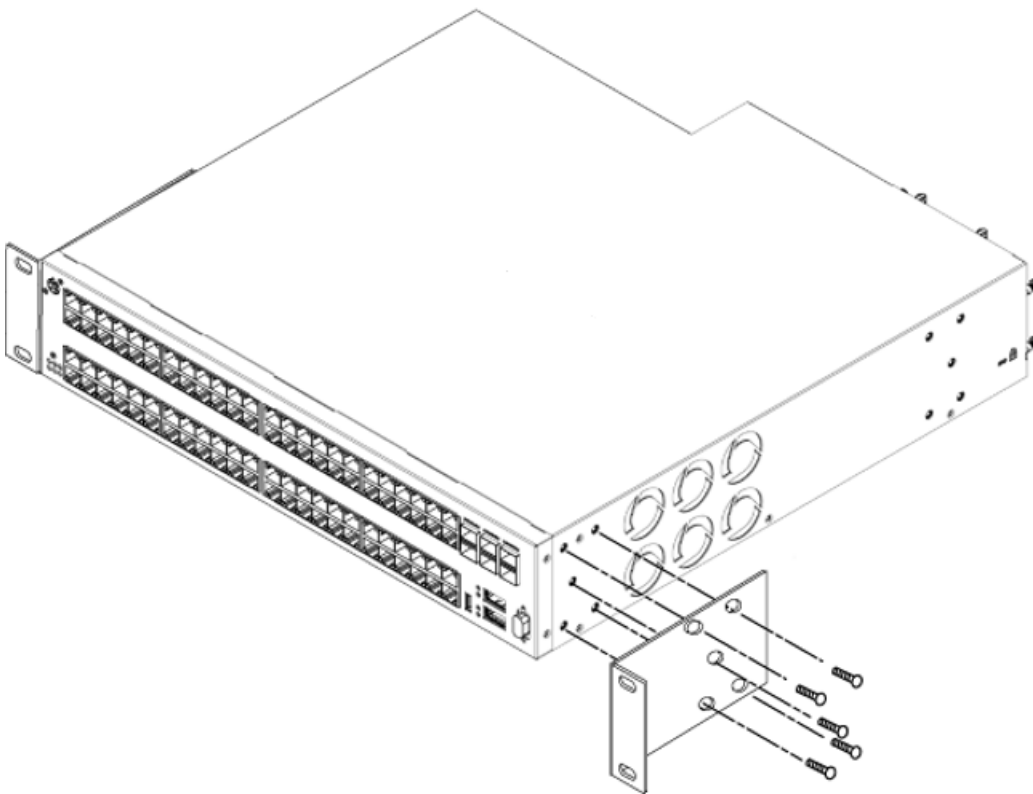
## Installing the switch in an equipment rack

Required tool: Phillips screwdriver for attaching brackets to the switch.

Rack requirements:

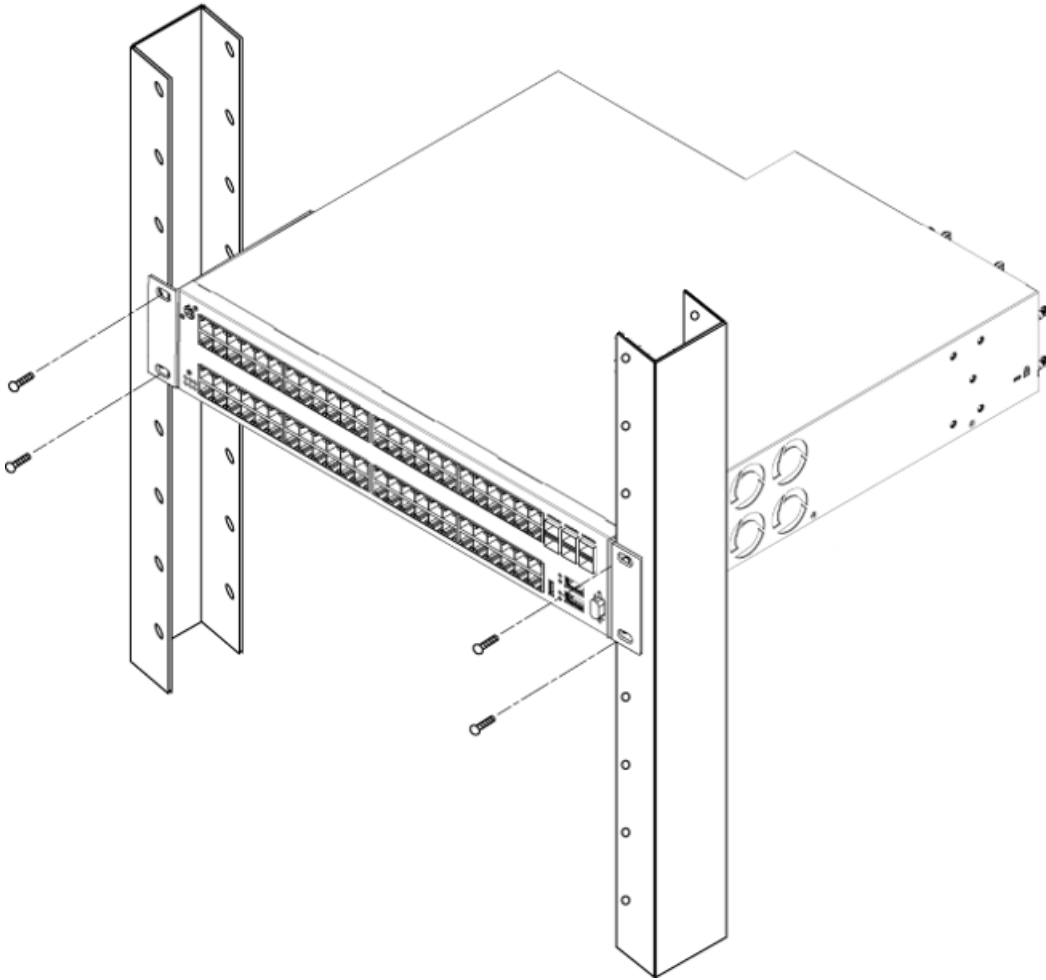
- A space of 2.8 inches (71.1 centimeters) for each switch in an EIA or IEC standard 19 inch (48.2 centimeter) equipment rack and TIA 23 inch (58.5 centimeter) equipment rack.
- Appropriate space to accommodate unit height:
  - ERS 5650 models require one rack unit (1.75 inches, 44.45 millimeters)
  - ERS 5632 models require 1.5 rack units (2.625 inches, 66.68 millimeters)
  - ERS 5698 models require 2 rack units (3.5 inches, 88.90 millimeters)
- The rack must be bolted to the floor, and braced if necessary.
- The rack must be grounded to the same grounding electrode used by the power service in the area. The ground path must be permanent and must not exceed 1 ohm of resistance from the rack to the grounding electrode.

The following figures illustrate installing the switch in a rack.



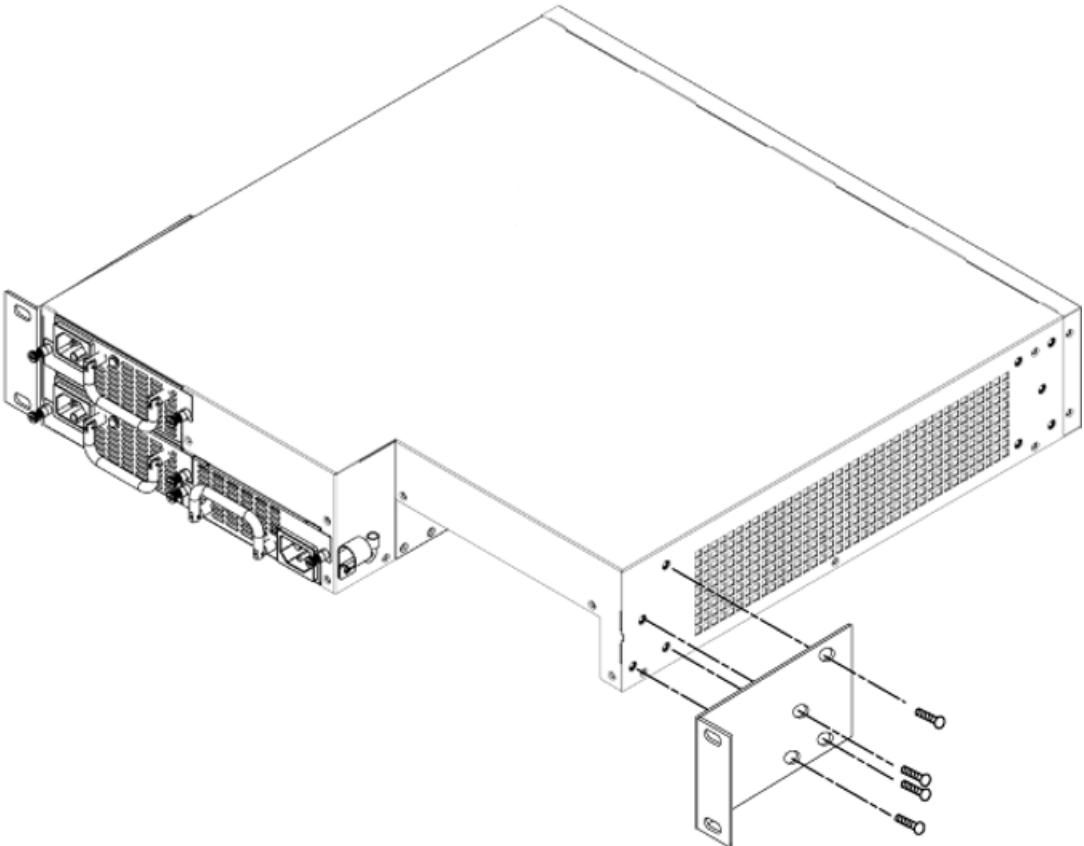
**Figure 1: Front-mounted rack bracket installation**

Attach a bracket to each side of the switch.



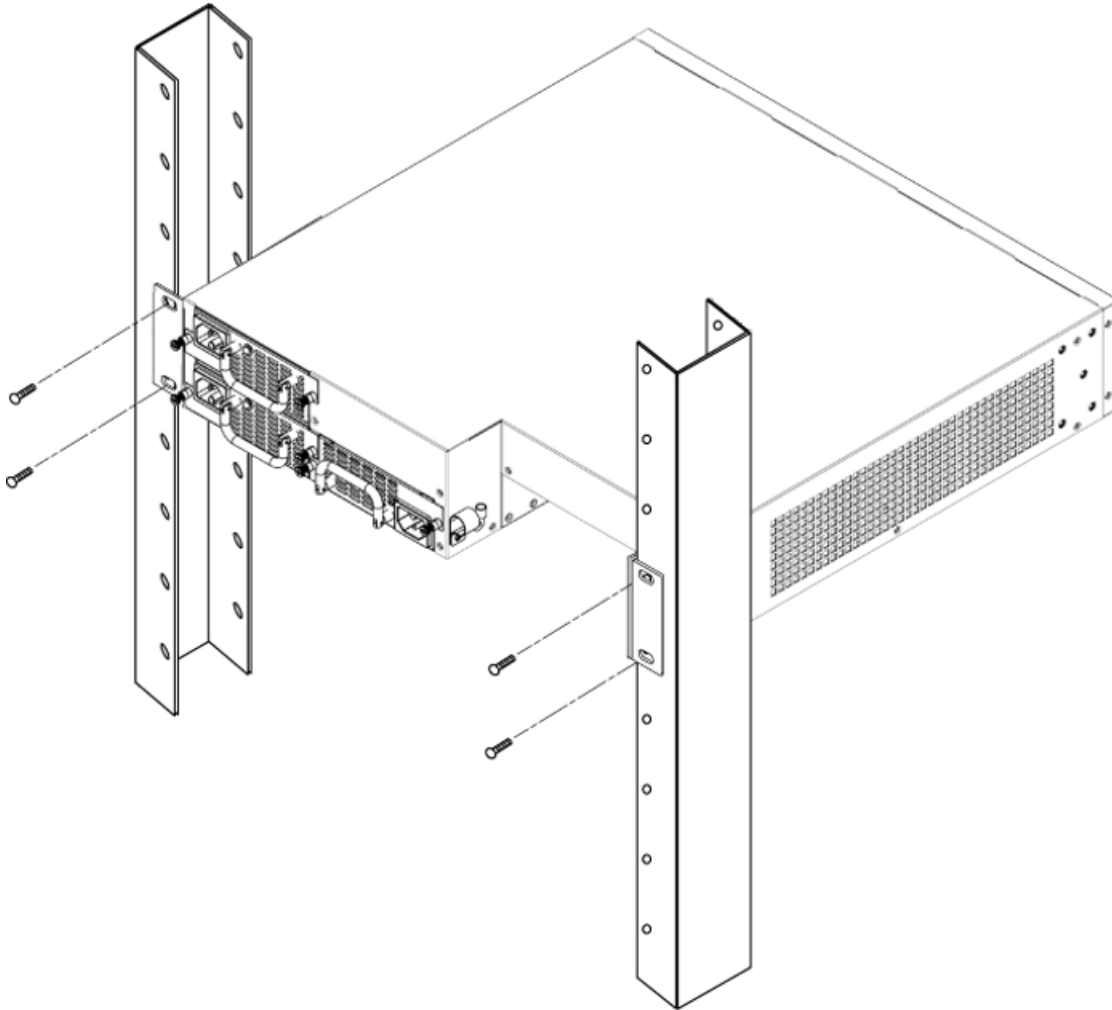
**Figure 2: Front-mounted rack installation**

Slide the switch into the rack. Insert and tighten the rack mount screws.



**Figure 3: Rear-mounted rack bracket installation**

Attach a bracket to each side of the switch.



**Figure 4: Rear-mounted rack installation**

Slide the switch into the rack. Insert and tighten the rack mount screws.

---

## AC and DC power specifications

The following table describes the AC and DC power specifications for the Ethernet Routing Switch 5600 Series.

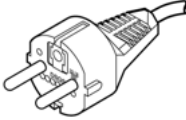
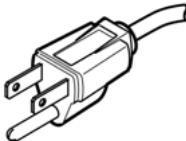
Model	Input current Amps maximum per power supply			Power consumption	Thermal rating	Power supply used	Power over Ethernet (PoE)
	100–120 VAC	48 VDC	200–240 VAC	Watts maximum	BTU/h maximum	Watts AC/DC, DC/DC	Power per port (Watts)
ERS 5632FD	1.8		0.9	190	650	300	n/a
ERS 5632FD DC		4.2		190	650	300	n/a
ERS 5650TD	1.2		0.6	132	450	300	n/a
ERS 5650TD DC		3.0	0.6	132	450	300	n/a
ERS 5650TD-PWR	5.5		2.75	218	745	600	8.0
ERS 5650TD-PWR DC	10.5		5.25	290	990	1000	15.4
ERS 5650 TD-PWR (2 power supplies)	5.3 *		2.65 *	290	990	600 *	15.4
ERS 5650 TD-PWR DC		21		290	990	1000	15.4
ERS 5698TFD	2.0		1.0	215	735	300	n/a
ERS 5698TFD DC		4.5		215	735	300	n/a
ERS 5698TFD-PWR	10.5		5.25	400	1365	1000	8
ERS 5698TFD-PWR (2 power supplies)	9.5 *		4.75 *	545	1850	1000 *	15.4

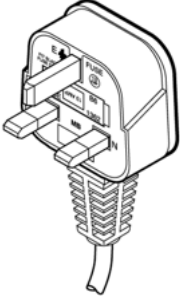
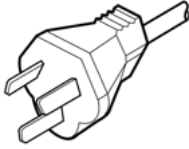
Model	Input current Amps maximum per power supply			Power consumption	Thermal rating	Power supply used	Power over Ethernet (PoE)
	100–120 VAC	48 VDC	200–240 VAC	Watts maximum	BTU/h maximum	Watts AC/DC, DC/DC	Power per port (Watts)
ERS 5698TFD-PWR DC		26		400	1365	1000	8
ERS 5698TFD-PWR DC (2 power supplies)		21 *		545	1850	1000 *	15.4
* per power supply							

## Connecting AC power

Required cable: AC power cord that meets the requirements of your local electrical code. Refer to the following table for plug specifications.

**Table 1: International power cord specifications**

Country and plug description	Specifications	Typical plug
Continental Europe <ul style="list-style-type: none"> <li>• CEE7 standard VII male plug</li> <li>• Harmonized cord (HAR marking on the outside of the cord jacket to comply with the CENELEC Harmonized Document HD-21)</li> </ul>	220 or 230 VAC 50 Hz Single phase	 228FA
U.S./Canada/Japan <ul style="list-style-type: none"> <li>• NEMA5-15P male plug</li> <li>• UL-recognized (UL stamped on cord jacket)</li> <li>• CSA-certified (CSA label secured to the cord)</li> </ul>	100 or 120 VAC 50-60 Hz Single phase	 227FA

Country and plug description	Specifications	Typical plug
United Kingdom • BS1363 male plug with fuse • Harmonized cord	240 VAC 50 Hz Single phase	 229FA
Australia AS3112-1981 male plug	240 VAC 50 Hz Single phase	 230FA

The Ethernet Routing Switch 5600 Series does not have a power switch. When you connect the AC power cord to a suitable AC power outlet, the switch powers up immediately.

Connect the AC power cord to the back of the switch, and then connect the cord to a power outlet. Ensure that you use the correct power cord for the switch and power supply.



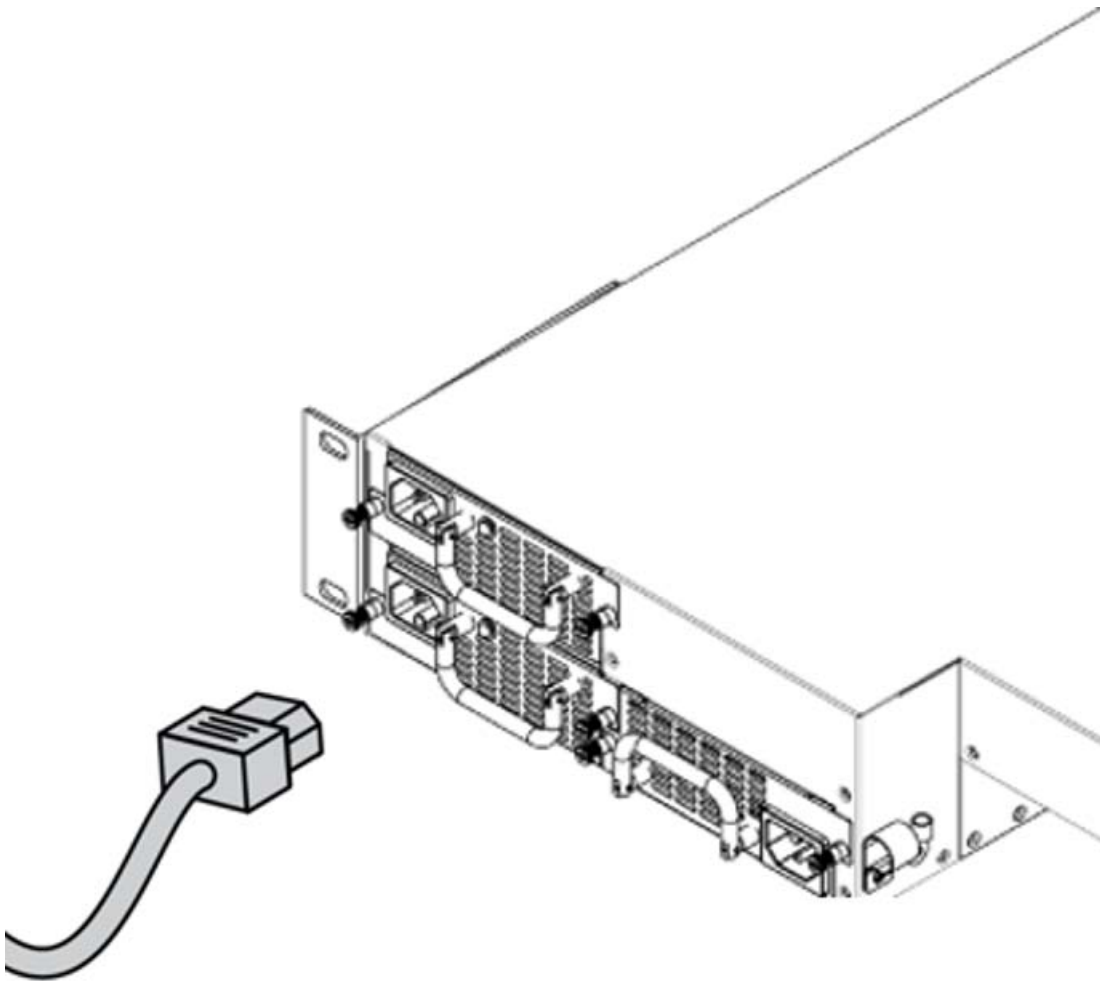


Figure 5: Connecting the AC power cord to the Ethernet Routing Switch 5600 Series

---

## Safety messages

 **Warning:**

Installation must be performed by qualified service personnel only. Read and follow all warning notices and instructions marked on the product or included in the documentation.

 **Voltage:**

This equipment relies on the building's installation for overcurrent protection. Ensure that a fuse or circuit breaker no larger than 120 VAC, 15 A U.S. (240 VAC, 16 A International) is used on the phase conductors.

 **Caution:**

This device is a Class A product. In a domestic environment, this device can cause radio interference, in which case the user may be required to take appropriate measures.

 **Caution:**

When mounting this device in a rack, do not stack units directly on top of one another in the rack. Each unit must be secured to the rack with appropriate mounting brackets. Mounting brackets are not designed to support multiple units.

 **Voltage:**

Use only power cords that have a grounding path. Without a proper ground, a person who touches the switch is in danger of receiving an electrical shock. Lack of a grounding path to the switch can result in excessive emissions.

 **Warning:**

Disconnecting the power cord is the only way to turn off power to this device. Always connect the power cord in a location that can be reached quickly and safely in case of an emergency.

 **Warning:**

Fiber optic equipment can emit laser or infrared light that can injure your eyes. Never look into an optical fiber or connector port. Always assume that fiber optic cables are connected to a light source.



 **Caution:**

Risk of explosion if battery is replaced by an incorrect type. Dispose of used batteries according to the instructions.

# Chapter 3: Deutsche

---

## Hinweise zur Verwendung

Achten Sie bei der Installation und Verwendung des Avaya ERS 5600 Series auf die folgenden äußeren Bedingungen:

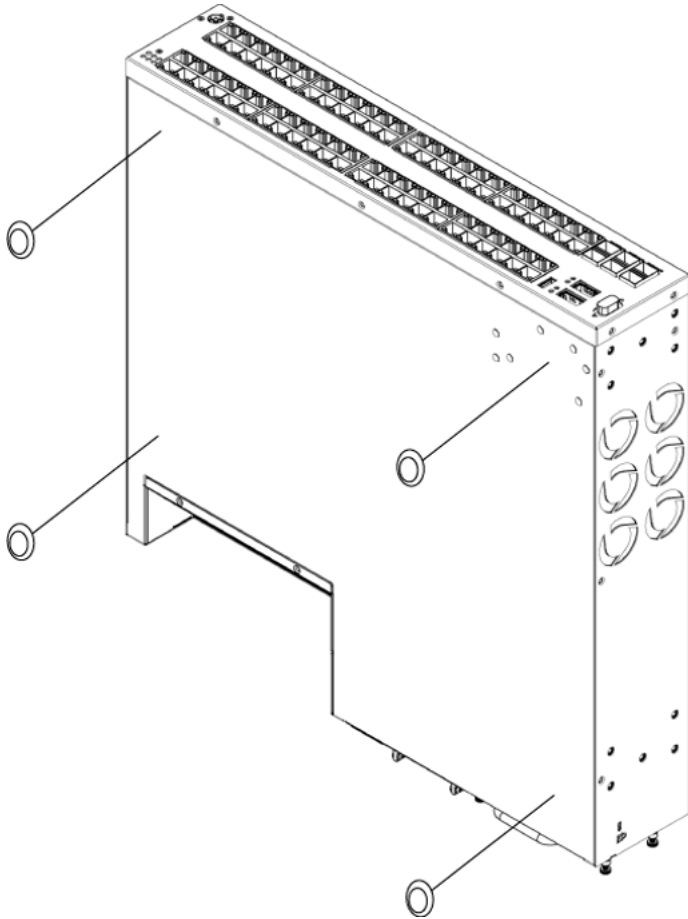
- Raumtemperatur zwischen 0° und 50° C
- relative Luftfeuchtigkeit zwischen 10% und 90% (nicht kondensierend)
- keine Hitzequellen, wie z. B. Heizungen oder direktes Sonnenlicht, in unmittelbarer Nähe
- keine elektromagnetischen Störungen in unmittelbarer Nähe
- keine Umgebungen mit starker Staubbildung
- Richtige Spannung Quelle innerhalb sechs Fußes; ein Stromkreis erfordert für jedes Spg.Versorgungsteil (sehen Sie Tabelle, Wechselstrom und DC Spannung Spezifikationen)
- mindestens 5 cm Abstand auf beiden Seiten der Schalteinheit für die Belüftung
- ausreichend Platz an der Vorder- und Rückseite der Einheit für Kabelzugriff

Wenn Sie einen einzelnen ERS 5600 Series auf einem Tisch oder Regal installieren möchten, muss die entsprechende Unterlage über eine Tragfähigkeit von mindestens 9,5-15 kg verfügen.

---

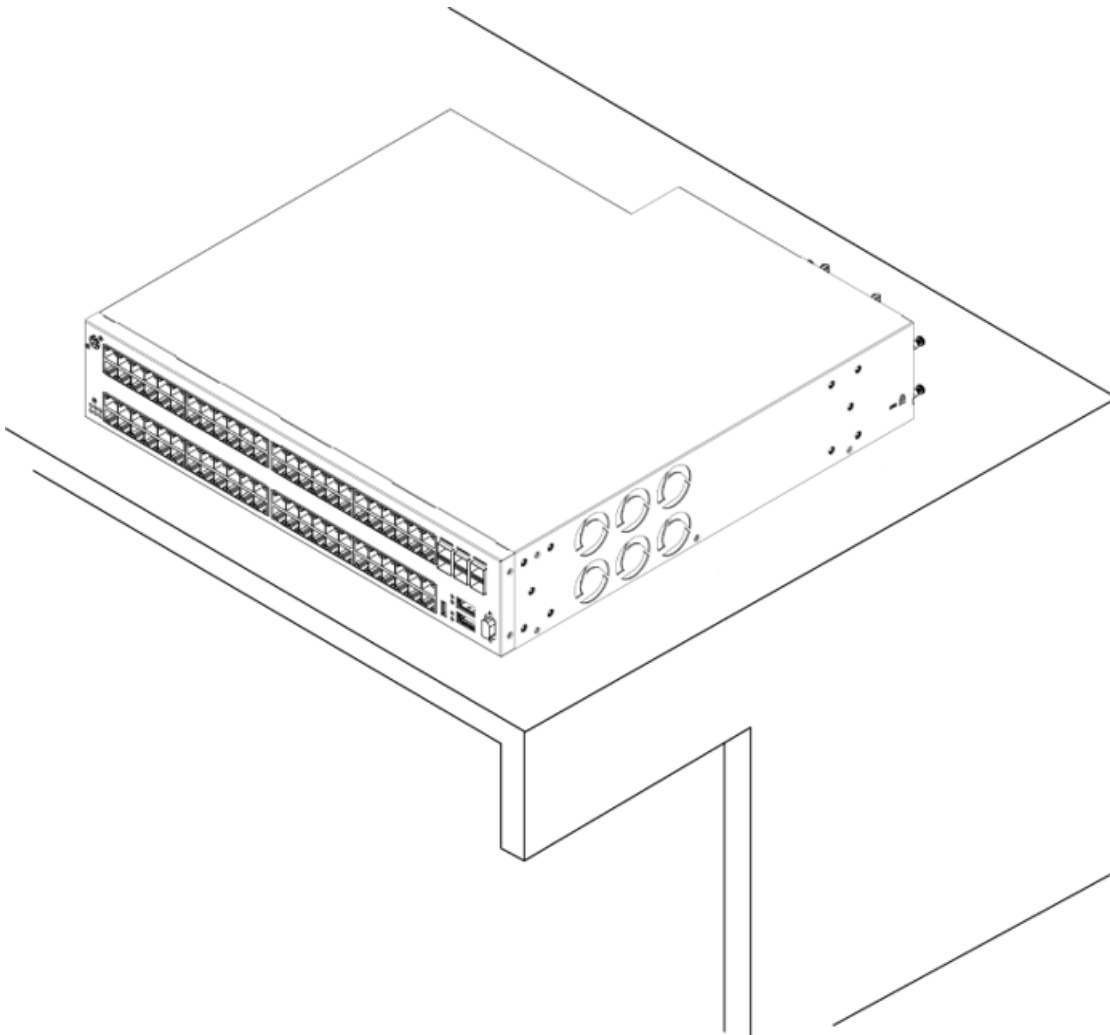
## Installation des Switch auf einem Tisch oder Regal

Sie können einen einzelnen ERS 5600 Series auf jeder ebenen Oberfläche installieren, die das Gewicht des Switch (9,5-15 kg) und der angeschlossenen Kabel tragen kann.



**Figure 6: Installation des Switch auf einem Tisch oder Regal**

Befestigen Sie die GummifüÙe an den angezeigten Stellen.



Stellen Sie den Switch auf einen Tisch oder Regal.

**⚠ Caution:**

Hinweis: Lassen Sie an den Seiten des Switch jeweils mindestens 5 cm für ausreichende Belüftung frei und auf der Rückseite mindestens 13 cm, um ausreichend Platz für die Kabel zu gewährleisten.

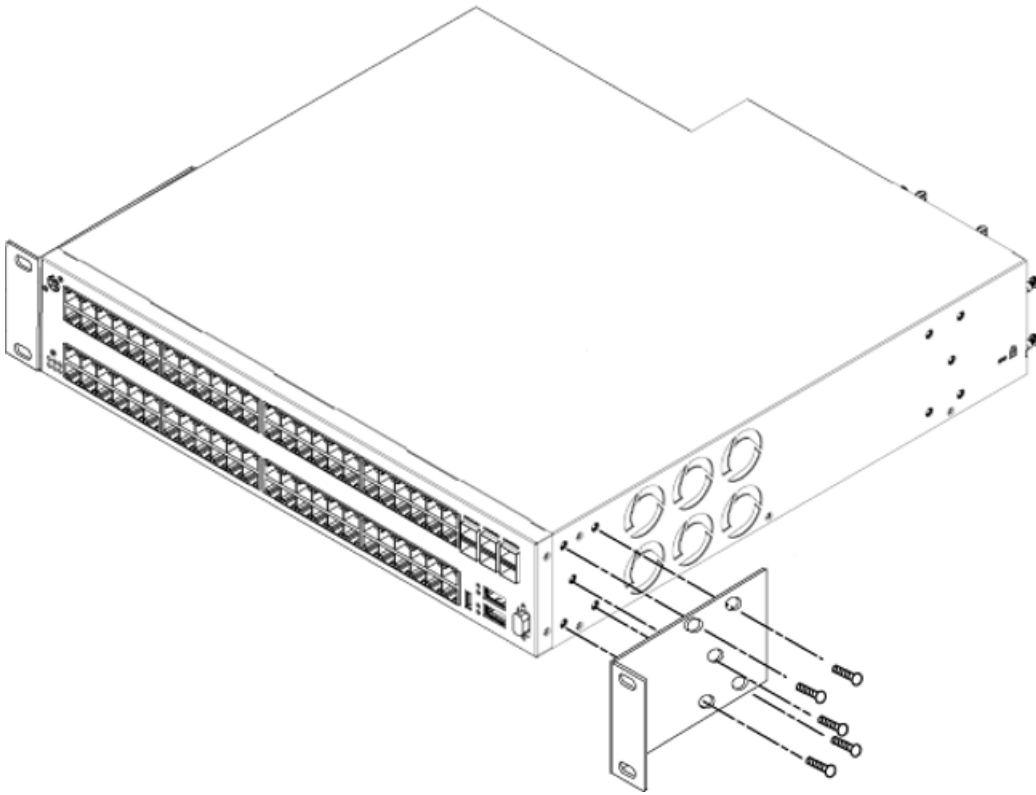
---

## Installation des Switch in einem Rack

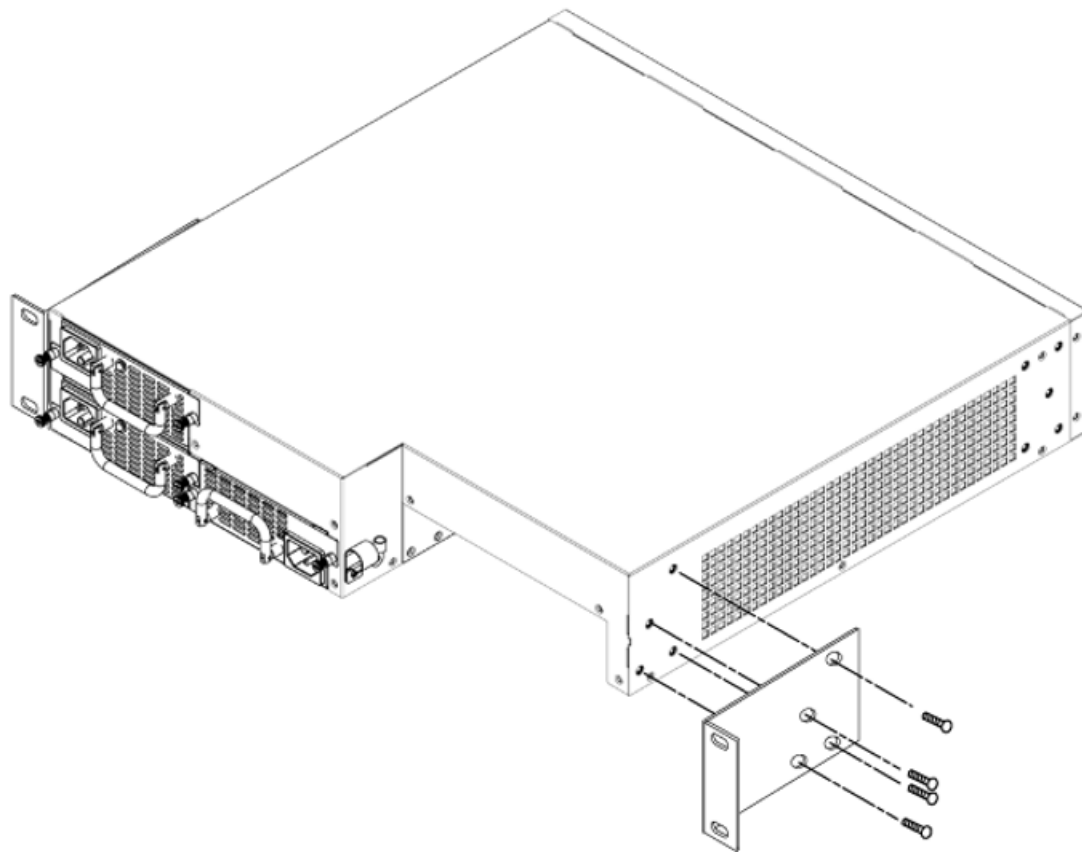
Benötigtes Werkzeug: Kreuzschraubendreher, um die Winkel am Switch zu befestigen

Voraussetzungen für die Installation in einem Rack:

- In einem EIA- oder IEC-Standardrack (19 Zoll) ist für jeden Switch eine Höhe von ca. 7 cm zu berechnen.
- Verwenden Sie Raum, um Maßeinheit Höhe unterzubringen:
  - ERS 5650 Modelle erfordern eine Zahnstange Maßeinheit (1,75 Zoll, 44,45 Millimeter)
  - ERS 5632 Modelle erfordern 1,5 Zahnstange Maßeinheiten (2,625 Zoll, 66,68 Millimeter)
  - ERS 5698 Modelle erfordern 2 Zahnstange Maßeinheiten (3,5 Zoll, 88,90 Millimeter)
- Das Rack muss ggf. am Boden und mit Winkeln an den Seiten verschraubt werden.
- Das Rack muss zu derselben Erdungselektrode geerdet sein, die auch von der Stromversorgung in der Umgebung verwendet wird. Die Erdung muss permanent sein und darf einen Widerstand von 1 Ohm vom Rack zur Erdungselektrode nicht überschreiten.

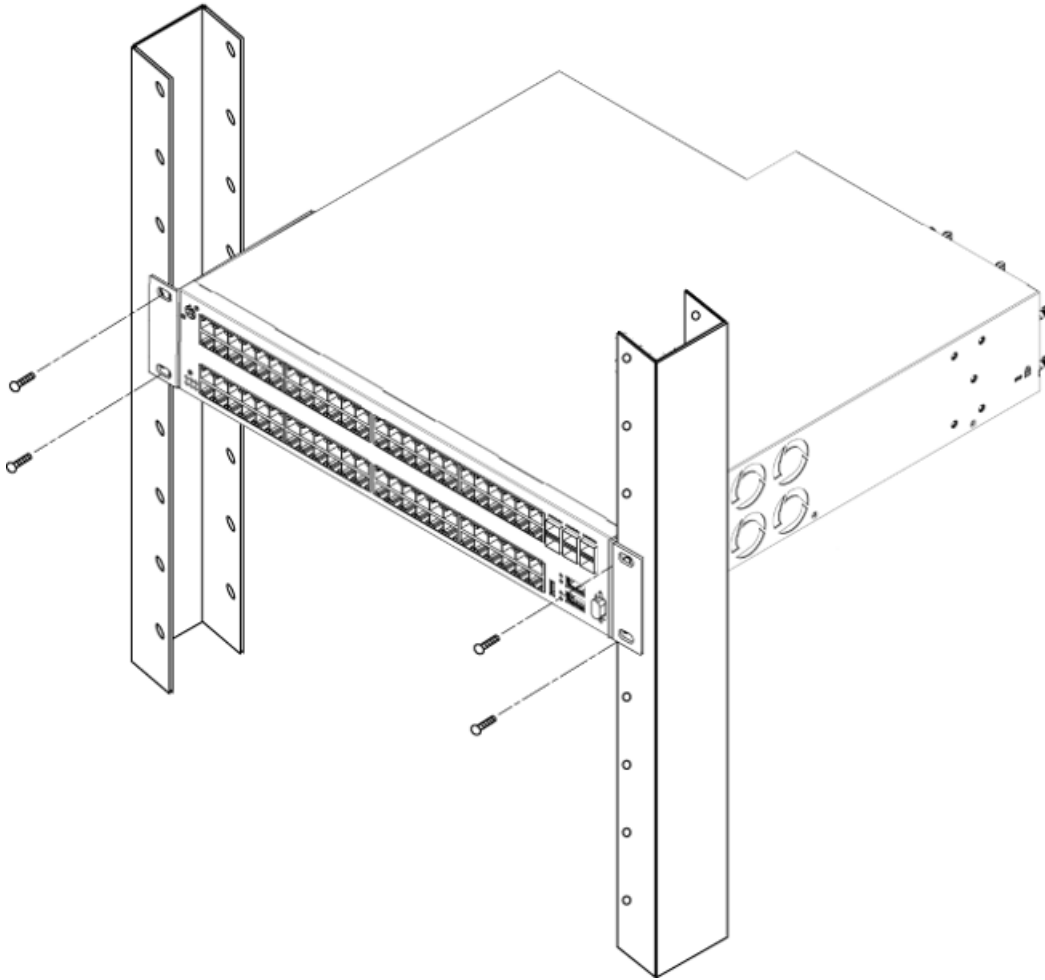


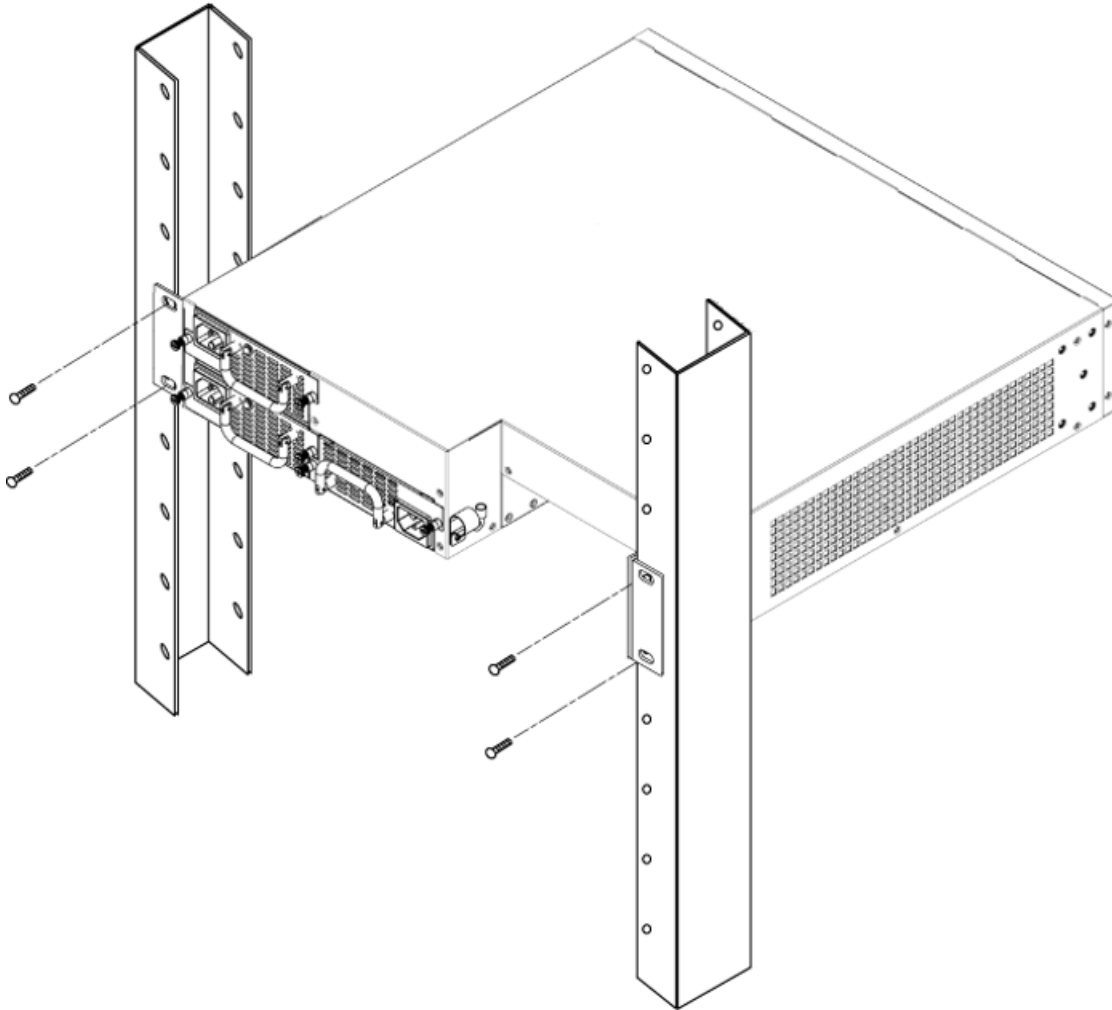
**Figure 7: Installation des Switch in einem Rack**



Bringen Sie auf jeder Seite des Switch einen Winkel an.







Führen Sie den Switch in das Rack ein. Befestigen Sie den Switch mit den dafür vorgesehenen Schrauben am Rack.

---

## Leistungsdaten

---

### Leistungsdaten (Wechselstrom und DC)

Die folgende Tabelle beschreibt die Wechselstrom und DC Energie Spezifikationen für das ERS 5600 Reihe.

**Table 2: Wechselstrom-Leistungsdaten: ERS 5600 Series**

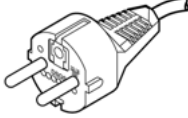
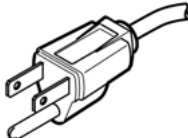
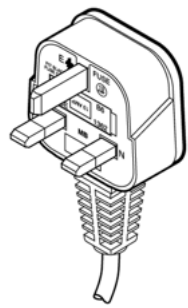
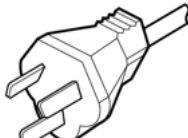
Modell	Eingangsstrom Ampere maximal pro Spg.Versorgungsteil			Leistungs- aufnahme	Thermisch e Belast- barkeit	Spg.Versor- gungs- - teil benutzt	Energie Über- Ethernet (PoE)
	100- 120 VAC	48 VDC	200-240 VAC	Watt maximal	BTU/h Maximum	Watts AC/DC, DC/DC	Energie pro Tor (Watt)
ERS 5632FD	1,8		0,9	190	650	300	n/a
ERS 5632FD DC		4,2		190	650	300	n/a
ERS 5650TD	1,2		0,6	132	450	300	n/a
ERS 5650TD DC		3,0	0,6	132	450	300	n/a
ERS 5650TD- PWR	5,5		2,75	218	745	600	8.0
ERS 5650TD- PWR DC	10,5		5,25	290	990	1000	15,4
ERS 5650 TD- PWR (2 Spg. Versor- gungs- teile)	5,3 *		2,65 *	290	990	600 *	15,4
ERS 5650 TD- PWR DC		21		290	990	1000	15,4
ERS 5698TF D	2,0		1,0	215	735	300	n/a
ERS 5698TF D DC		4,5		215	735	300	n/a

Modell	Eingangsstrom Ampere maximal pro Spg.Versorgungsteil			Leistungs- aufnahme  Watt maximal	Thermisch e Belast- barkeit  BTU/h Maximum	Spg.Ver- sorgungs- - teil benutzt  Watts AC/DC, DC/DC	Energie Über- Ethernet (PoE)  Energie pro Tor (Watt)
	100- 120 VAC	48 VDC	200-240 VAC				
ERS 5698TF D-PWR	10,5		5,25	400	1365	1000	8
ERS 5698TF D-PWR (2 Spg. Versor- gungs- teile)	9,5 *		4,75 *	545	1850	1000 *	15,4
ERS 5698TF D-PWR DC		26		400	1365	1000	8
ERS 5698TF D-PWR DC (2 Spg. Versor- gungs- teile)		21 *		545	1850	1000 *	15,4
* pro Spg.Versorgungsteil							

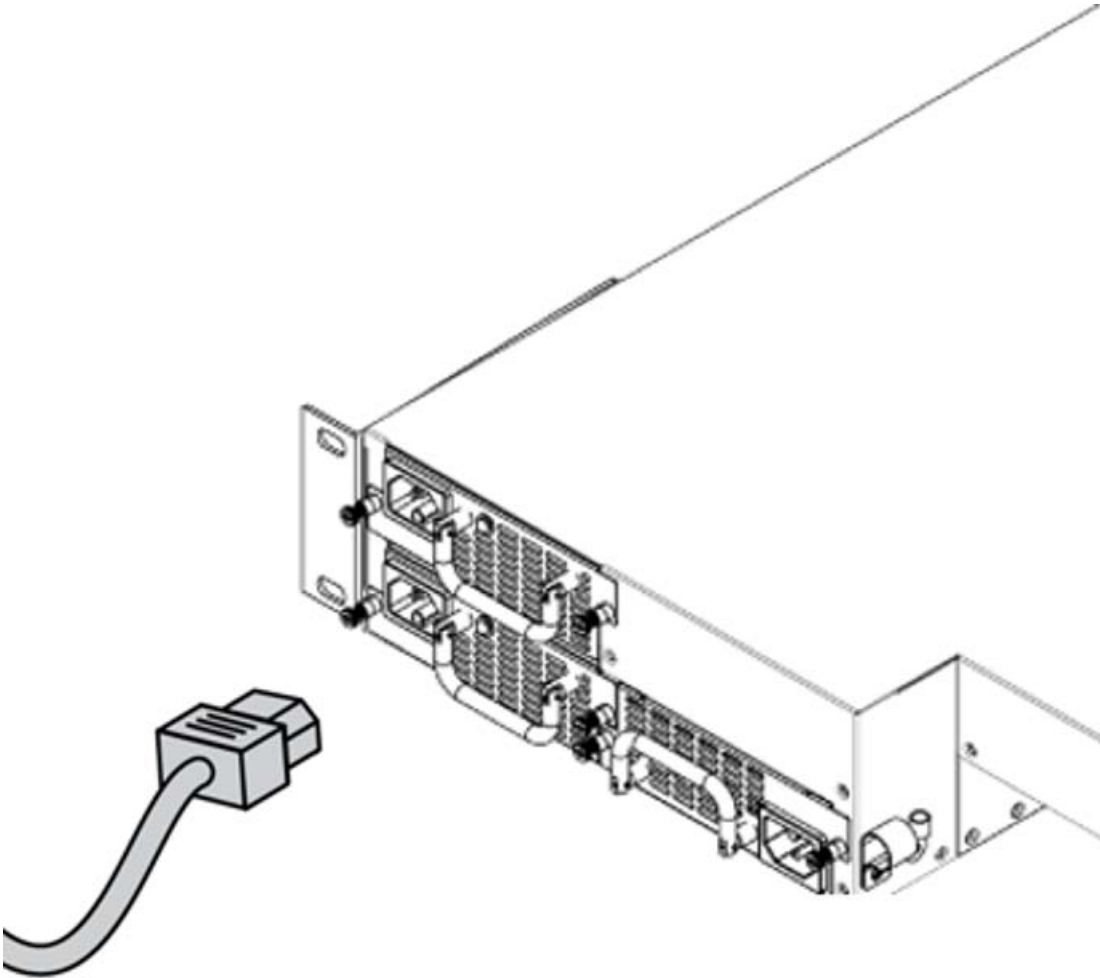
## Wechselstrom-Anschluss

Erforderliches Kabel: Stromkabel (Wechselstrom), das die örtlichen elektrischen Sicherheitsvorschriften erfüllt. Angaben zu den einzelnen Netzsteckern finden Sie in.

**Table 3: Internationale Angaben zu Stromkabeln**

Land/Steckerbeschreibung	Angaben	Typischer Netzstecker
Europa (Kontinent): <ul style="list-style-type: none"> <li>• Stecker CEE7 Standard VII</li> <li>• abgeglichenes Kabel (Markierung HAR auf der Außenseite des Kabels nach CENELEC Harmonized Document HD-21)</li> </ul>	220 oder 230 V Wechselstrom 50 Hz einphasig	 228FA
USA/Kanada/Japan: <ul style="list-style-type: none"> <li>• Stecker NEMA5-15P UL-geprüft</li> <li>• (UL-Stempel auf der Außenseite des Kabels)</li> <li>• CSA-zertifiziert (CSA-Label am Kabel angebracht)</li> </ul>	100 oder 120 V Wechselstrom 50-60 Hz einphasig	 227FA
Großbritannien: <ul style="list-style-type: none"> <li>• Stecker BS1363 mit Sicherung</li> <li>• abgeglichenes Kabel</li> </ul>	240 V Wechselstrom 50 Hz einphasig	 229FA
Australien: Stecker AS3112-1981	240 V Wechselstrom 50 Hz einphasig	 230FA

Der ERS 5600 Series hat keinen Netzschalter. Wenn Sie das Stromkabel an eine geeignete Steckdose anschließen, wird der Switch automatisch eingeschaltet. Die Abbildung zeigen, wie Sie das Stromkabel am ERS 5600 Series anschließen.



**Figure 8: Anschluss des Stromkabels (Wechselstrom) am ERS 5600 Series**

Schließen Sie das Stromkabel an der Rückseite des Switch an, und stecken Sie das Kabel dann in eine Steckdose.

---

## Sicherheitsinformationen

 **Warning:**

Warnung: Die Installation darf nur von qualifiziertem Servicepersonal durchgeführt werden. Lesen und befolgen Sie alle Warnhinweise und Anleitungen, die auf dem Produkt ausgewiesen oder in der Dokumentation enthalten sind.

**⚠ Danger:**

Gefahr: Diese Ausstattung setzt voraus, dass die jeweilige Einrichtung vor Überstrom geschützt ist. Achten Sie darauf, dass die Spannung der Sicherung oder des Schutzschalters, die für die Phasenleiter verwendet wird, nicht mehr als 240 V Wechselstrom, 16 A beträgt.

**⚠ Caution:**

Achtung: Dieses Gerät ist ein Produkt der Klasse A. In Wohngebieten kann das Gerät Hochfrequenzstörungen verursachen. In diesem Fall muss der Benutzer geeignete Maßnahmen ergreifen.

**⚠ Caution:**

Achtung: Wenn Sie das Gerät in einem Rack installieren, platzieren Sie Einheiten im Rack nicht direkt übereinander. Jede Einheit im Rack muss mit dafür geeigneten Winkeln befestigt werden. Die Winkel sind nicht dazu geeignet, mehrere Einheiten zu tragen.

**⚠ Danger:**

Gefahr: Verwenden Sie nur geerdete Stromkabel. Ohne Erdung besteht die Gefahr, dass eine Person beim Berühren des Switch einen elektrischen Schlag erhält. Das Fehlen einer Erdung zum Switch kann übermäßige Emissionen zur Folge haben.

**⚠ Warning:**

Warnung: Der Strom für dieses Gerät kann nur durch Herausziehen des Stromkabels abgeschaltet werden. Schließen Sie das Stromkabel stets an einer Steckdose an, die Sie in einem Notfall schnell und sicher erreichen können.

**⚠ Warning:**

Warnung: Glasfaser-Ausrüstung kann Laser oder Infrarotlicht abgeben, die Ihre Augen beschädigen können. Sehen Sie nie direkt in eine Glasfaser oder einen Verbindungsport. Denken Sie stets daran, dass Glasfaserkabel an eine Lichtquelle angeschlossen sein können.

**⚠ Danger:**

Achtung: Gefahr der Explosion, wenn Batterie nach einer falschen Art ersetzt wird. Entleeren Sie sich benutzte Batterien entsprechend den Anweisungen.





# Chapter 4: Español

---

## Antes de comenzar

Asegúrese de que el área donde va a instalar y utilizar el Avaya ERS 5600 Series cumple los siguientes requisitos medioambientales:

- Temperatura ambiente entre 0° y 50° C (32° y 106° F)
- Humedad relativa entre el 10% y el 90%, sin condensación
- No estar cerca de fuentes de calor como conductos de aire caliente ni de la luz directa del sol
- No estar cerca de fuentes con altos niveles de ruido electromagnético
- No contener niveles de polvo excesivos
- Fuente de energía adecuada a seis pies (1,8 metros); un circuito requerido para cada fuente de alimentación (véase las especificaciones de la tabla, de la potencia cc de la CA y)
- Disponer de al menos 5,08 cm (2 pulgadas) a cada lado de la unidad del conmutador para ventilación
- Disponer de espacio suficiente en la parte delantera y posterior del conmutador para poder acceder a los cables

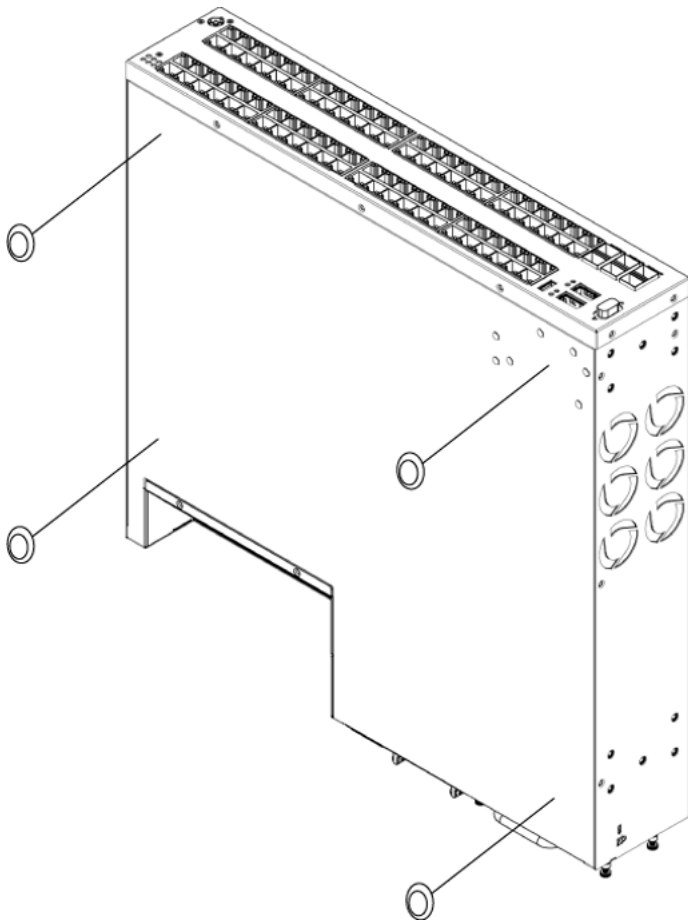
Si desea instalar un ERS 5600 Series en una mesa o estantería, asegúrese de que la superficie puede soportar al menos de 9,5 a 15 kg (de 21 a 33 libras).

---

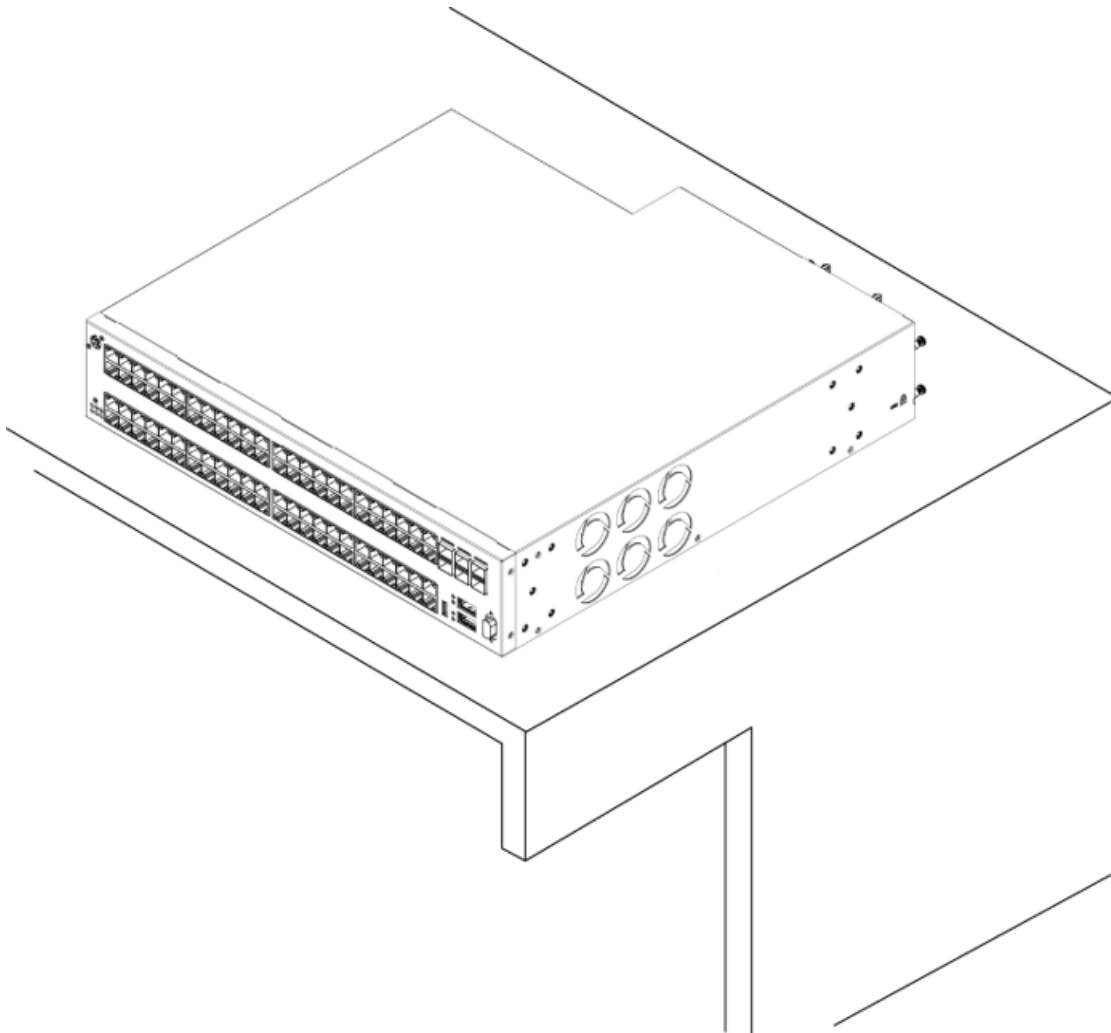
## Instalación del conmutador en una mesa o estantería

Puede instalar un ERS 5600 Series en cualquier superficie plana que pueda soportar de forma segura el peso del conmutador y de los cables que lo acompañan (de 9,5 a 15 kg o de 21 a 33 libras).

La figura se proporcionan instrucciones sobre cómo instalar el conmutador en una mesa o estantería.



Fije las patillas de goma en los lugares marcados.



Coloque el conmutador en una mesa o estantería.

**\* Note:**

Nota: deje al menos 5,1 cm (2 pulg.) a cada lado para que el dispositivo pueda ventilarse de forma correcta y 12,7 cm (5 pulg.) en la parte posterior para el cable de alimentación.

---

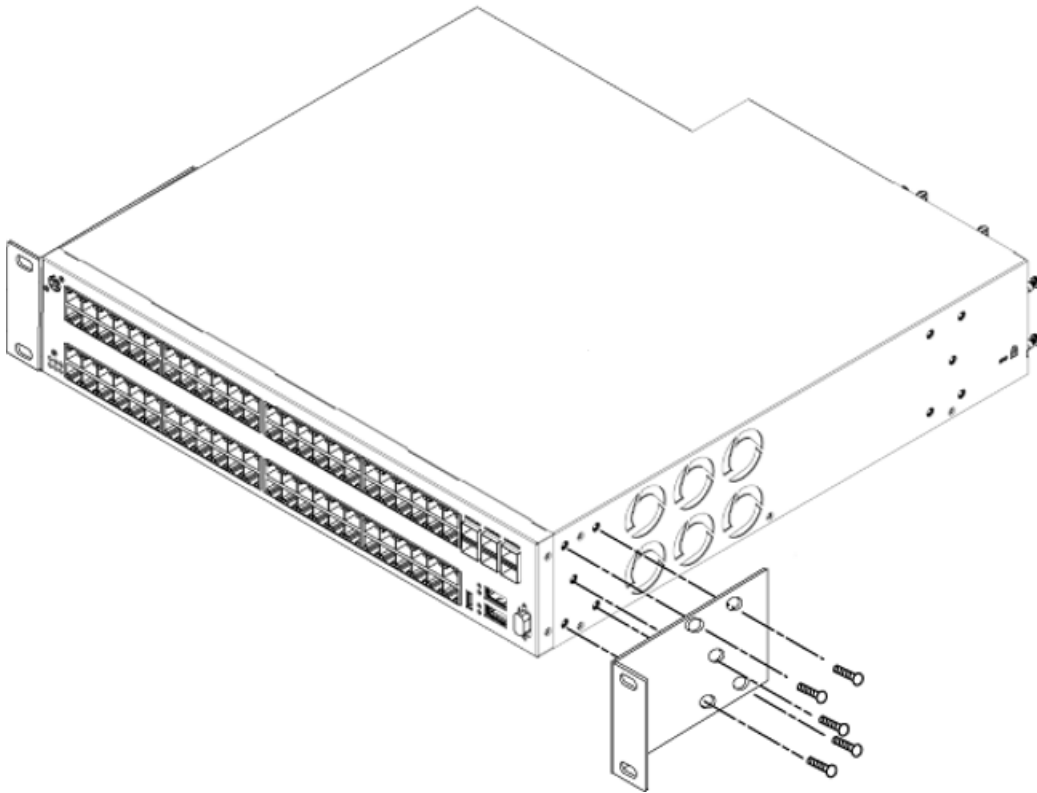
## Instalación del conmutador en un bastidor para equipos

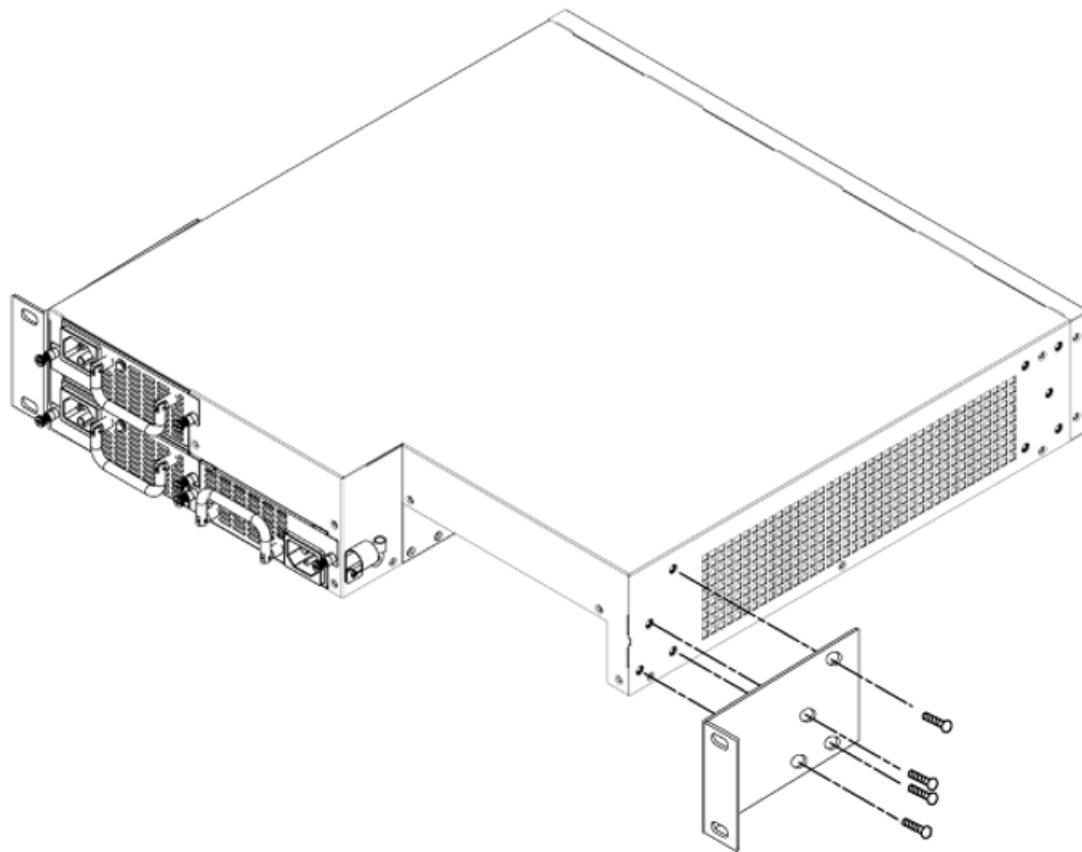
Herramienta necesaria: destornillador Phillips para unir los soportes al conmutador

Requisitos del bastidor:

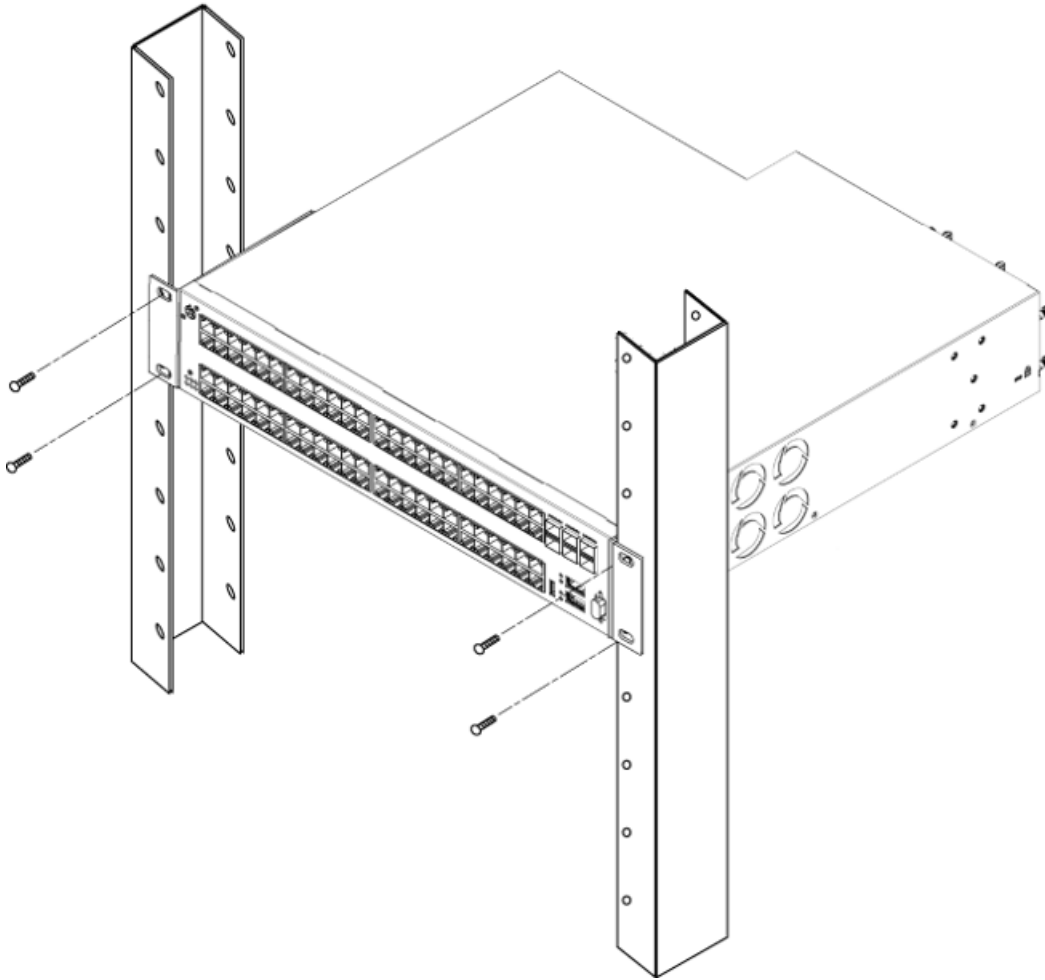
- Se necesita un espacio de 6 cm (2,8 pulg.) para cada conmutador en un bastidor para equipos de 48,2 cm (19 pulg.) que cumpla con la norma EIA o IEC.
- Apropíese del espacio para acomodar altura de la unidad:
  - Los modelos de ERS 5650 requieren una unidad del estante (1,75 pulgadas, 44,45 milímetros)
  - Los modelos de ERS 5632 requieren 1,5 unidades del estante (2,625 pulgadas, 66,68 milímetros)
  - Los modelos de ERS 5698 requieren 2 unidades del estante (3,5 pulgadas, 88,90 milímetros)
- El bastidor debe estar atornillado al suelo y anclado, si es necesario.
- El bastidor debe estar conectado a tierra con el mismo electrodo de conexión a tierra utilizado por el servicio eléctrico de la zona. La conexión a tierra debe ser permanente y no deberá superar 1 ohmio de resistencia desde el bastidor hasta el electrodo de conexión a tierra.

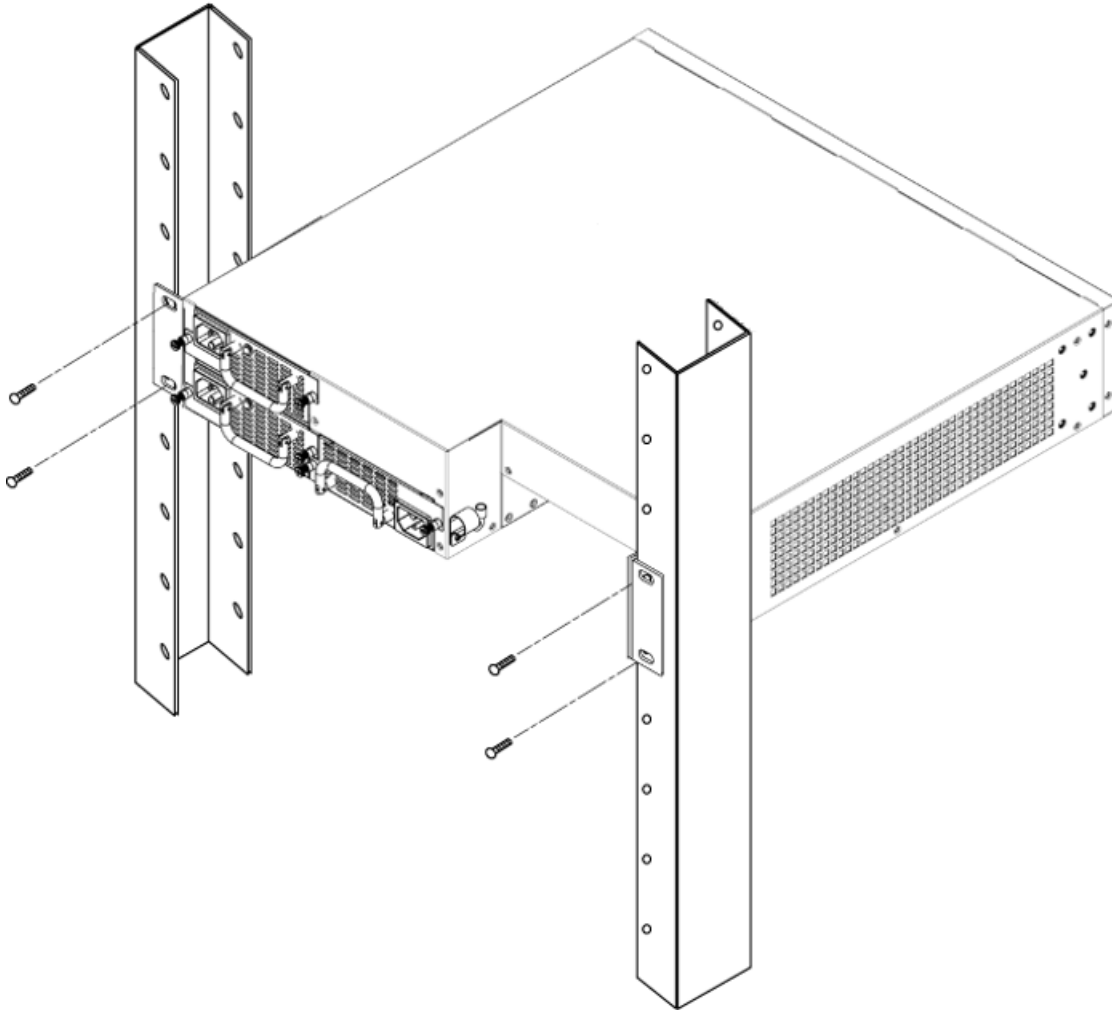
En la Figura se proporcionan instrucciones sobre cómo instalar el conmutador en un bastidor.





Coloque un soporte a cada lado del conmutador.





Introduzca el conmutador en el bastidor. Introduzca y apriete los tornillos para el montaje en bastidor.

---

## Especificaciones eléctricas

---

## Especificaciones de la potencia cc de la CA y

La tabla siguiente describe las especificaciones de la potencia cc de la CA y Para el ERS 5600 series.



**Table 4: Especificaciones eléctricas ERS 5600**

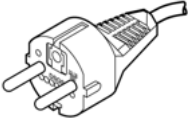
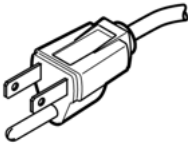
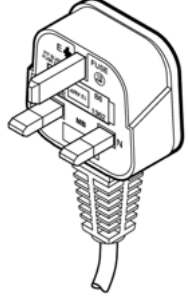
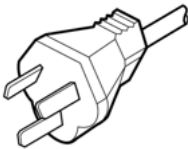
Modelo	Corriente de entrada Maximo			Consumo de energía Maximo W	Nivel térmico BTU/h maximo	Fuente de alimentación usada Watts AC/DC, DC/DC	Ethernet excesiva de la energía (PoE) Energía por el puerto (vatios)
	100-120 VAC	48 VDC	200-240 VAC				
ERS 5632FD	1,8		0,9	190	650	300	n/a
ERS 5632FD DC		4,2		190	650	300	n/a
ERS 5650TD	1,2		0,6	132	450	300	n/a
ERS 5650TD DC		3,0	0,6	132	450	300	n/a
ERS 5650TD -PWR	5,5		2,75	218	745	600	8.0
ERS 5650TD -PWR DC	10,5		5,25	290	990	1000	15,4
ERS 5650 TD-PWR (2 fuentes de alimentación)	5,3 *		2,65 *	290	990	600 *	15,4
ERS 5650 TD-PWR DC		21		290	990	1000	15,4
ERS 5698TF D	2,0		1,0	215	735	300	n/a
ERS 5698TF D DC		4,5		215	735	300	n/a

Modelo	Corriente de entrada Maximo			Consumo de energía Maximo W	Nivel térmico BTU/h maximo	Fuente de alimentación usada Watts AC/DC, DC/DC	Ethernet excesiva de la energía (PoE) Energía por el puerto (vatios)
	100-120 VAC	48 VDC	200-240 VAC				
ERS 5698TF D-PWR	10,5		5,25	400	1365	1000	8
ERS 5698TF D-PWR (2 fuentes de alimentación)	9,5 *		4,75 *	545	1850	1000 *	15,4
ERS 5698TF D-PWR DC		26		400	1365	1000	8
ERS 5698TF D-PWR DC (2 fuentes de alimentación)		21 *		545	1850	1000 *	15,4
* por fuente de alimentación							

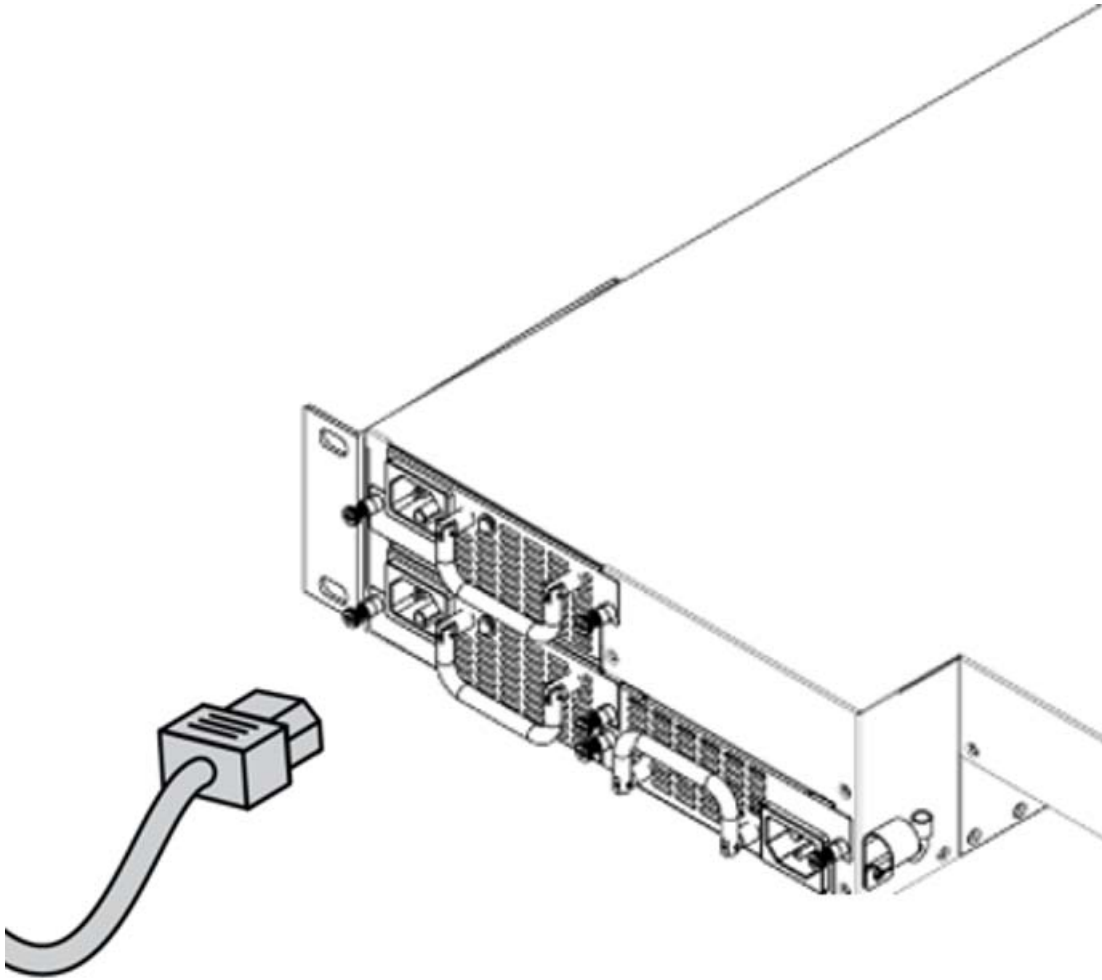
## Conexión a CA

Cable necesario: cable de alimentación de CA que cumpla los requisitos del código eléctrico local. Consulte la tabla para obtener información sobre los enchufes.

**Table 5: Especificaciones internacionales sobre clases de alimentación**

País/descripción del enchufe	Especificaciones	Enchufe típico
Europa continental: <ul style="list-style-type: none"> <li>• Enchufe macho CEE7 estándar VII</li> <li>• Cable armonizado (marca HAR en el exterior de la funda para cumplir con el documento de armonización HD-21 de CENELEC)</li> </ul>	220 o 230 V CA 50 Hz Monofásico	 <p style="text-align: center;">228FA</p>
EE.UU./Canadá/Japón: <ul style="list-style-type: none"> <li>• Enchufe macho NEMA5-15P</li> <li>• Reconocido por UL (UL impreso en la funda del cable)</li> <li>• Certificado por CSA (etiqueta de CSA en el cable)</li> </ul>	100 o 120 V CA 50-60 Hz Monofásico	 <p style="text-align: center;">227FA</p>
Reino Unido: <ul style="list-style-type: none"> <li>• Enchufe macho BS1363 con fusible</li> <li>• Cable armonizado</li> </ul>	240 V CA 50 Hz Monofásico	 <p style="text-align: center;">229FA</p>
Australia: Enchufe macho AS3112-1981	240 V CA 50 Hz Monofásico	 <p style="text-align: center;">230FA</p>

El ERS 5600 Series no dispone de un interrupto de alimentación. Al conectar el cable de alimentación d CA a un conector de entrada CA adecuada, el conmutador se activa inmediatamente. La figura se muestra cómo conectar el cable de alimentación al ERS 5600 Series.



---

## Mensajes de seguridad

**⚠ Warning:**

Aviso: sólo el personal de servicio cualificado puede realizar la instalación. Lea y siga todos los avisos e instrucciones de advertencia grabados en el producto o incluidos en la documentación.

**⚠ Danger:**

Peligro: este equipo confía en la instalación del edificio para la protección contra sobrecargas. Asegúrese de que en los conductores de fase se utiliza un fusible o un disyuntor de menos de 240 V CA, 16 A internacional (120 V CA, 15 A en EE.UU.).

 **Caution:**

Precaución: este dispositivo es un producto de Clase A. En un entorno doméstico, este dispositivo puede causar radiointerferencias, en cuyo caso se le puede solicitar al usuario que tome las medidas apropiadas.

 **Caution:**

Precaución: al montar este dispositivo en un bastidor, no apile las unidades directamente una encima de otra. Cada unidad debe estar fijada al bastidor con los soportes de montaje apropiados. Los soportes de montaje no están diseñados para soportar varias unidades.

 **Danger:**

Peligro: utilice sólo cables de alimentación que tengan conexión a tierra. Sin una toma de tierra adecuada, cualquier persona que toque el conmutador estará en peligro de recibir una descarga eléctrica. La no existencia de una conexión a tierra puede dar lugar a emisiones excesivas.

 **Warning:**

Aviso: el único modo de apagar este dispositivo es desconectando el cable de alimentación. Conecte siempre el cable de alimentación en un lugar que sea de acceso rápido y seguro en caso de emergencia.

 **Warning:**

Aviso: el equipamiento de fibra óptica puede emitir luz láser o infrarroja que puede dañar los ojos. No mire nunca a través de un puerto de fibra óptica ni de un puerto conector. Tenga en cuenta siempre que los cables de fibra óptica están conectados a una fuente de luz.

 **Caution:**

Precaución: Riesgo de la explosión si la batería es substituida por un tipo incorrecto. Disponga de las baterías usadas según las instrucciones.



# Chapter 5: Français

---

## Avant de commencer

Assurez-vous que l'endroit où vous installez le commutateur Avaya ERS 5600 Series et où vous l'utiliserez soit conforme aux conditions environnementales suivantes:

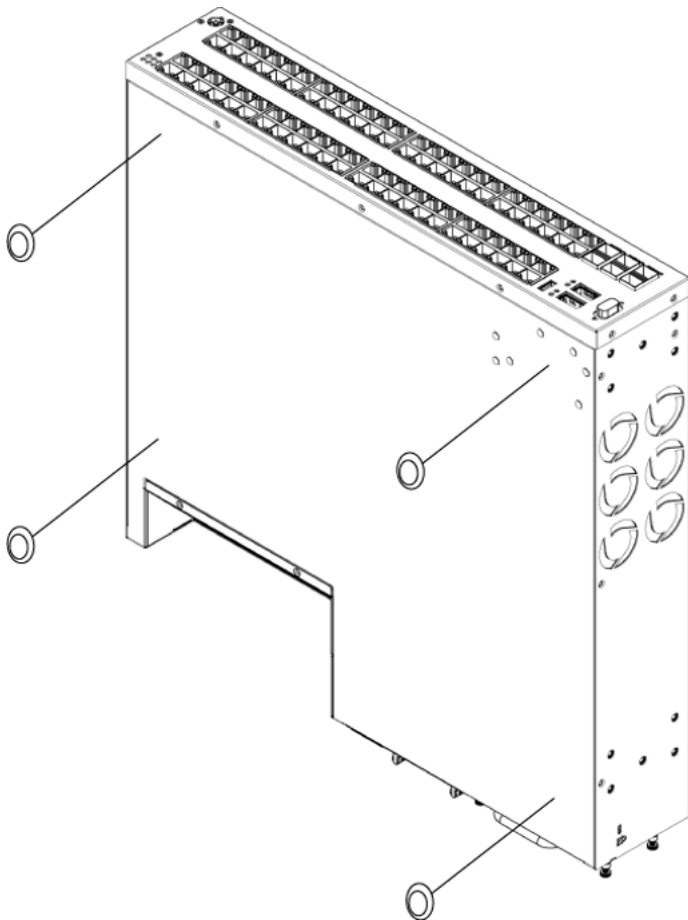
- Température ambiante entre 0° et 50° C (32° et 106° F)
- Humidité relative entre 10 % et 90 % sans condensation
- Aucune source de chaleur à proximité, comme par exemple une ventilation chaude ou la lumière directe du soleil
- Aucune source de bruit électromagnétique à proximité
- Pas de poussière excessive
- Source d'énergie proportionnée à moins de six pieds (1,8 mètre) ; un circuit requis pour chaque alimentation d'énergie (voir les caractéristiques de table, d'alimentation CC à C.A. et)
- Distance minimale de 5,08 cm (2 po) de chaque côté de l'unité de commutation pour la ventilation
- Espace approprié à l'avant et à l'arrière du commutateur pour faciliter l'accès aux câbles.

Si vous installez un seul commutateur ERS 5600 Series sur une table ou sur une étagère, assurez-vous que cette surface puisse supporter un poids d'au moins 9,5 à 15 kg (21 à 33 livres).

---

## Installation du commutateur sur une table ou sur une étagère

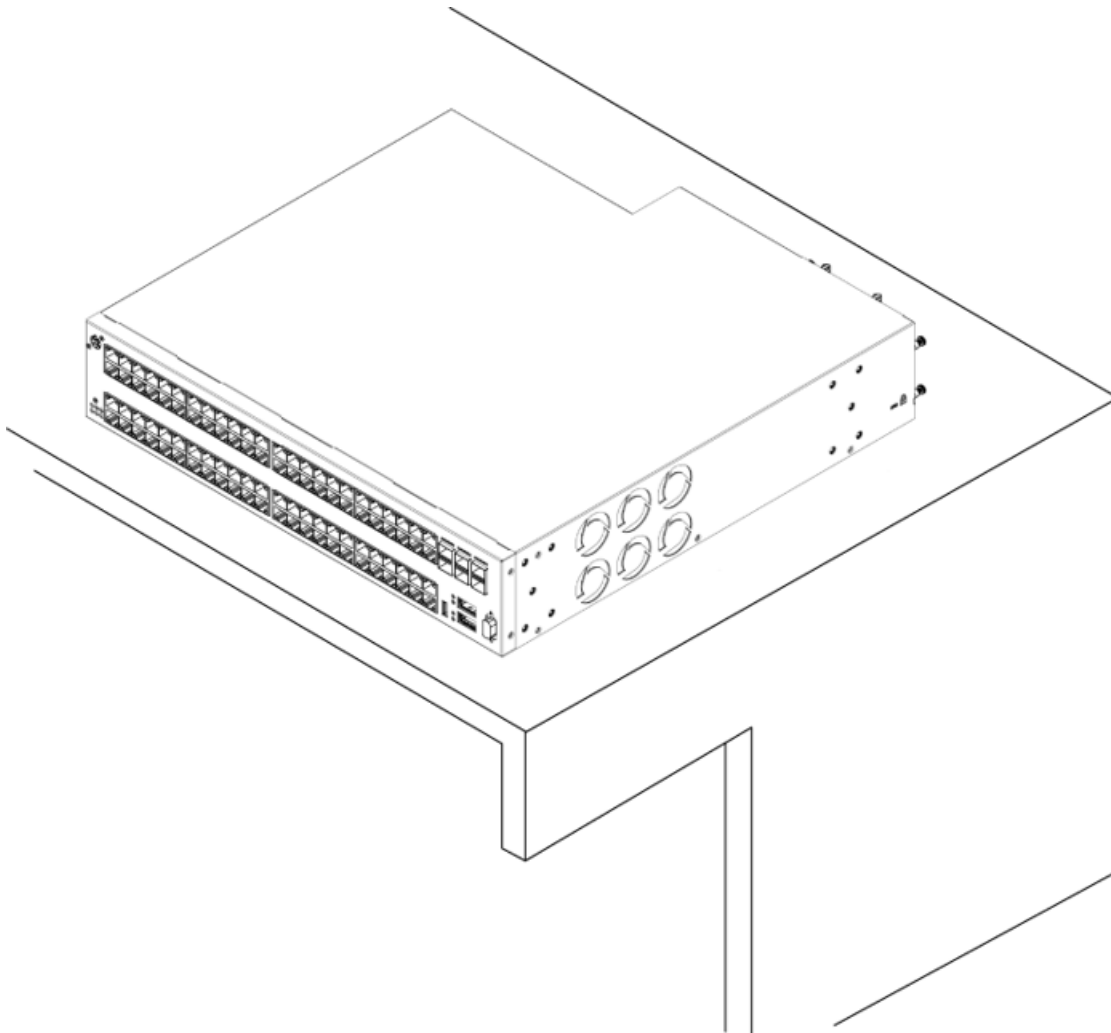
Vous pouvez installer un commutateur ERS 5600 Series sur toute surface plane pouvant supporter le poids du commutateur et des câbles reliés 9,5 à 15 kg (21 à 33 livres). La figure fournit des instructions sur l'installation du commutateur sur une table ou sur une étagère.



**Figure 9: Installation du commutateur sur une table ou sur une étagère**

Fixez les pieds en caoutchouc aux emplacements indiqués.





Installation du commutateur sur une table.

**\* Note:**

Remarque: Laissez au moins 5,1 cm (2 po) de chaque côté pour la ventilation et 12,7 cm (5 po) à l'arrière pour le dégagement du cordon d'alimentation.

---

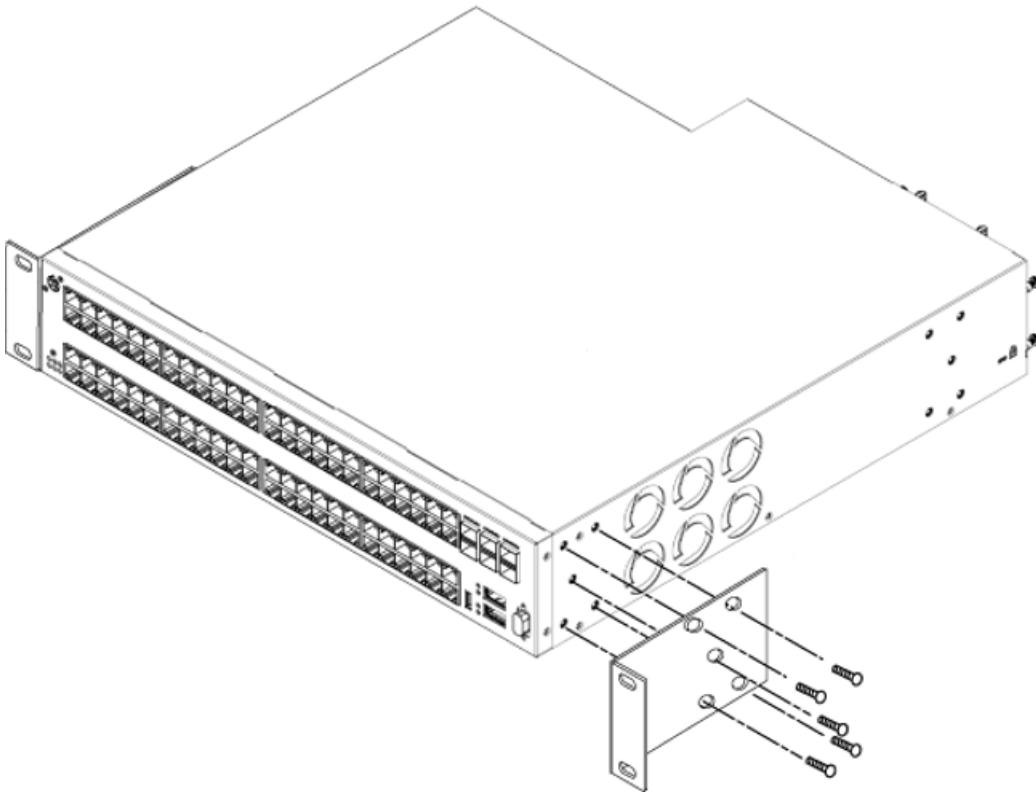
## Installation du commutateur dans un rack

Outil nécessaire: Un tournevis Philips pour attacher les supports au commutateur.

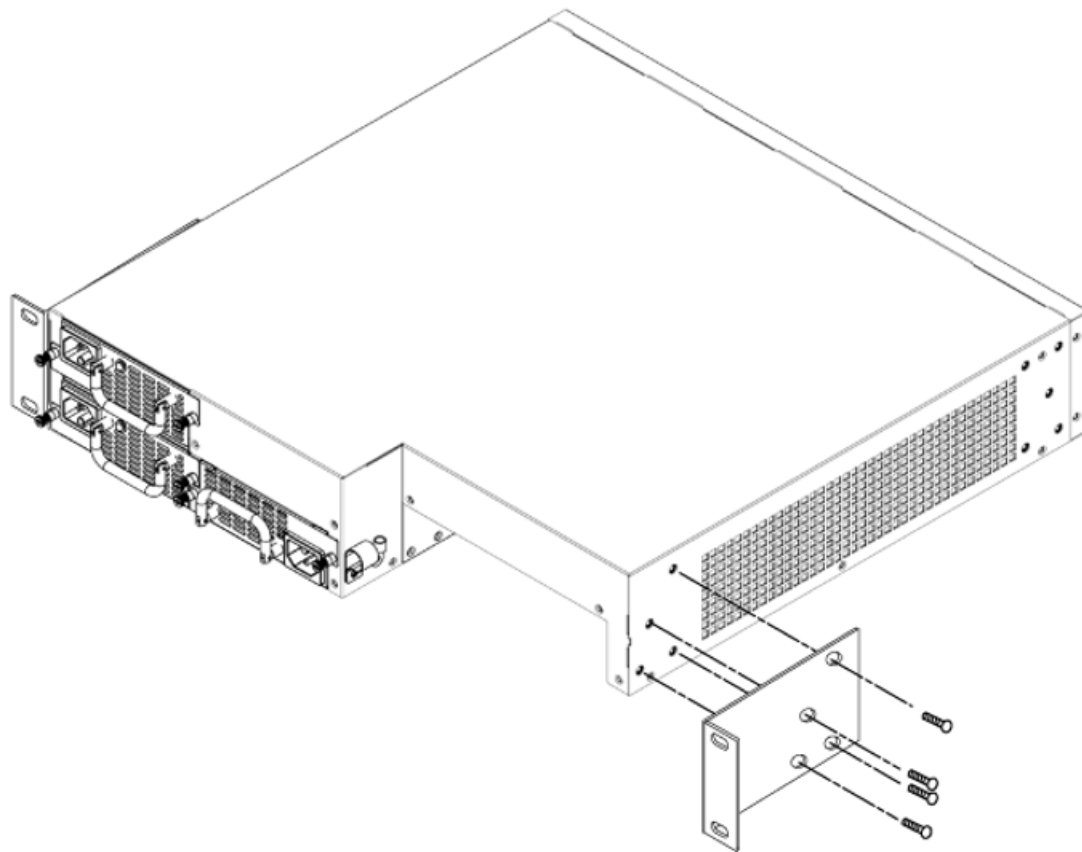
Configuration pour un rack:

- Un espace de 8,5 cm (2,8 po) est nécessaire pour chaque commutateur dans un rack EIA ou IEC standard de 48 cm (19 po).
- Appropriiez-vous l'espace pour adapter à la taille d'unité :
  - Les modèles d'ERS 5650 exigent une unité de support (1,75 pouce, 44,45 millimètres)
  - Les modèles d'ERS 5632 exigent 1,5 unité de support (2,625 pouces, 66,68 millimètres)
  - Les modèles d'ERS 5698 exigent 2 unités de support (3,5 pouces, 88,90 millimètres)
- Le rack doit être boulonné au sol et calé si nécessaire.
- Le rack doit être mis à la terre au même conducteur de terre que celui utilisé par le service d'alimentation de l'endroit. Le conducteur de terre doit être permanent et ne doit pas dépasser 1 Ohm de résistance du rack au conducteur de terre.

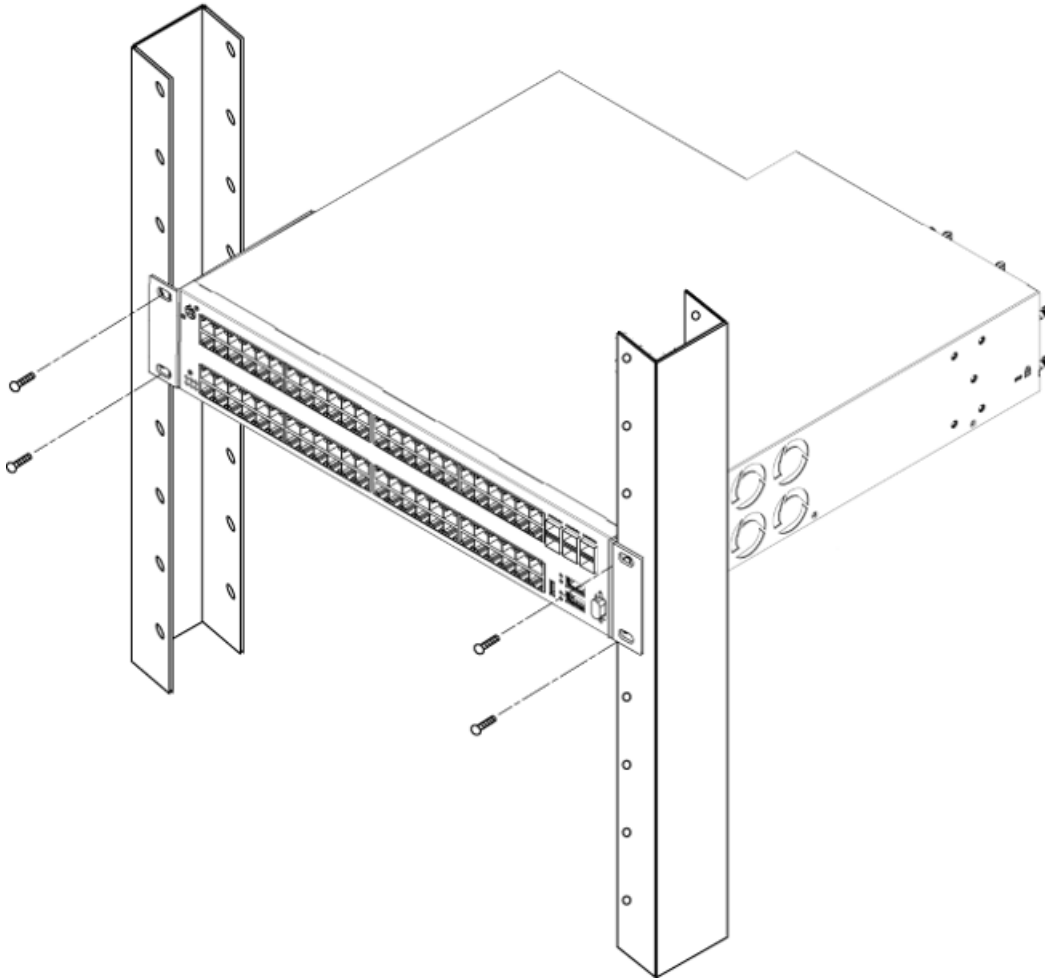
La figure fournit des instructions sur l'installation du commutateur dans un rack.

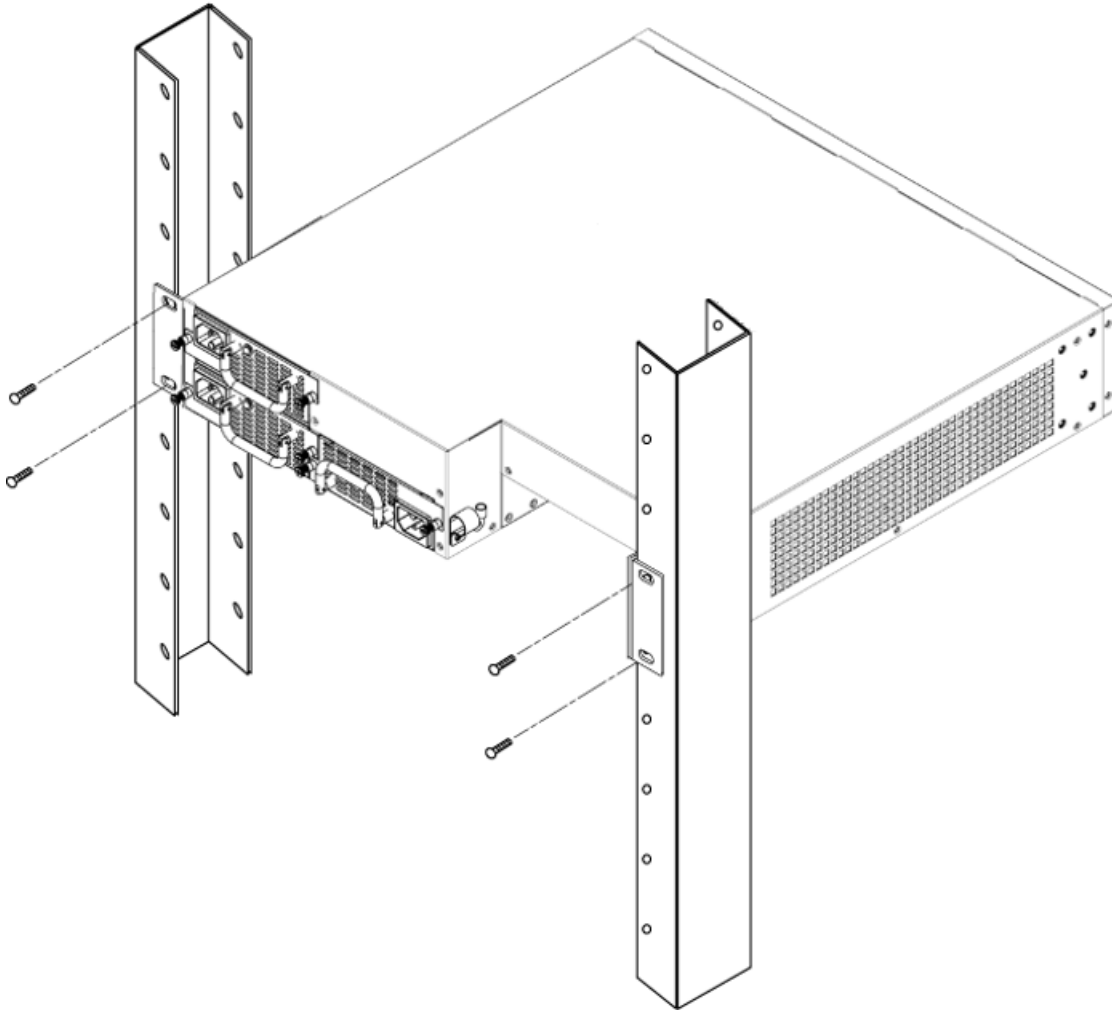


**Figure 10: Installation du commutateur dans un rack**



Fixez un support de chaque côté du commutateur.





Glissez le commutateur dans le rack. Insérez les vis de montage en rack et serrez-les.

---

## Alimentation: Caractéristiques

---

## Alimentation secteur: caractéristiques

La table suivante décrit les caractéristiques d'alimentation secteur du ERS 5600 Series.

**Table 6: Alimentation secteur du ERS 5600: caractéristiques**

Modèle	Courant d'entrée Ampères maximum par alimentation d'énergie			Consommation d'énergie	Puissance thermique	Energie por el puerto (vatios)	Ethernet fini de puissance (PoE)
	100- 120 VAC	48 VDC	200-240 VAC	Watts maximum	BTU/h maximum	Watts AC/DC, DC/DC	Puissance par port (watts)
ERS 5632FD	1,8		0,9	190	650	300	n/a
ERS 5632FD DC		4,2		190	650	300	n/a
ERS 5650TD	1,2		0,6	132	450	300	n/a
ERS 5650TD DC		3,0	0,6	132	450	300	n/a
ERS 5650TD-PWR	5,5		2,75	218	745	600	8.0
ERS 5650TD-PWR DC	10,5		5,25	290	990	1000	15,4
ERS 5650 TD-PWR (2 alimentations d'énergie)	5,3 *		2,65 *	290	990	600 *	15,4
ERS 5650 TD-PWR DC		21		290	990	1000	15,4
ERS 5698TF D	2,0		1,0	215	735	300	n/a
ERS 5698TF D DC		4,5		215	735	300	n/a

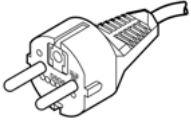
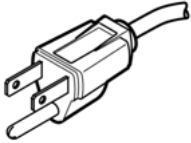
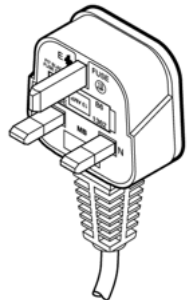
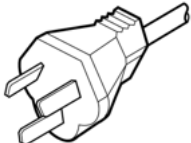
Modèle	Courant d'entrée Ampères maximum par alimentation d'énergie			Consommation d'énergie	Puissance thermique	Energía por el puerto (vatios)	Ethernet fini de puissance (PoE)
	100- 120 VAC	48 VDC	200-240 VAC	Watts maximum	BTU/h maximum	Watts AC/DC, DC/DC	Puissance par port (watts)
ERS 5698TF D-PWR	10,5		5,25	400	1365	1000	8
ERS 5698TF D-PWR (2 alimentations d'énergie)	9,5 *		4,75 *	545	1850	1000 *	15,4
ERS 5698TF D-PWR DC		26		400	1365	1000	8
ERS 5698TF D-PWR DC (2 alimentations d'énergie)		21 *		545	1850	1000 *	15,4
* par alimentation d'énergie							

## Alimentation secteur: connexion

Câble requis: Un cordon d'alimentation conforme aux conditions de votre code électrique local. Reportez-vous au tableau pour les caractéristiques des prises.



**Table 7: Cordons secteurs internationaux: caractéristiques**

Pays/Description de la prise	Caractéristiques	Prise habituelle
Europe continentale: <ul style="list-style-type: none"> <li>• Prise mâle CEE7 standard VII</li> <li>• Cordon harmonisé (une marque HAR sur l'extérieur du cordon montre la conformité au document harmonisé CENELEC HD-21)</li> </ul>	220 ou 230 Vca 50Hz Monophasé	 228FA
États-Unis/Canada/Japon: <ul style="list-style-type: none"> <li>• Prise mâle NEMA5-15P</li> <li>• Reconnu par UL (Cachet UL sur le cordon)</li> <li>• Certifié CSA (étiquette CSA fixée sur le cordon)</li> </ul>	100 ou 120 Vca 50-60 Hz Monophasé	 227FA
Royaume-Uni: <ul style="list-style-type: none"> <li>• Prise mâle BS1363 avec fusible</li> <li>• Cordon harmonisé</li> </ul>	240 Vca 50 Hz Monophasé	 229FA
Australie: Prise mâle AS3112-1981	240 Vca 50 Hz Monophasé	 230FA

ERS 5600 Series ne possède pas de commutateur d'alimentation. Lorsque vous connectez le cordon d'alimentation à une sortie d'alimentation secteur appropriée, le commutateur s'allume immédiatement. La figure décrit la manière de connecter le câble d'alimentation au ERS 5600 Series.

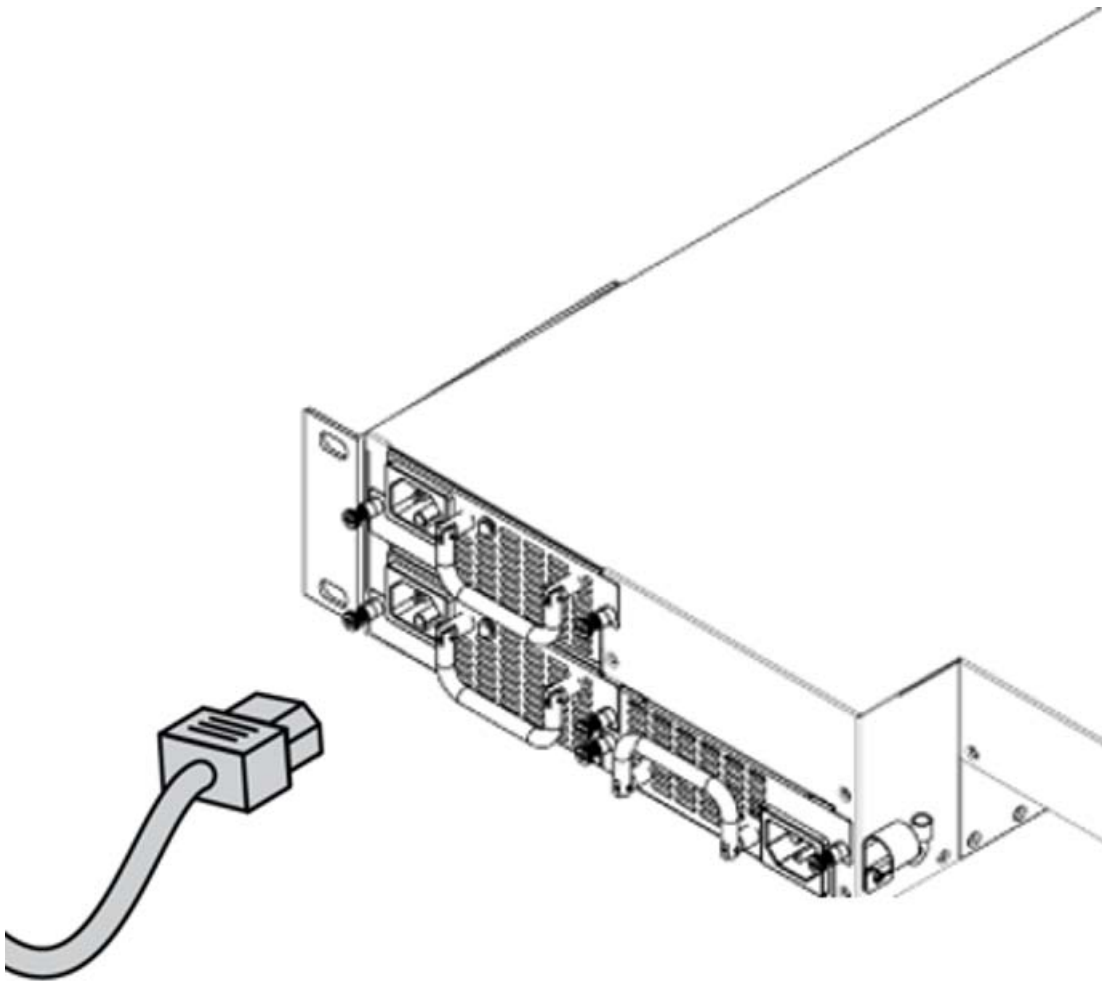


Figure 11: Connexion du cordon secteur au ERS 5600 Series

Connectez le cordon d'alimentation à l'arrière du commutateur, puis à une source d'alime

---

## Messages de sécurité

 **Warning:**

Avertissement: L'installation ne doit être effectuée que par des personnes qualifiées. Lisez toutes les notices et instructions d'avertissement indiquées sur le produit ou dans la documentation et suivez-les.

**⚠ Danger:**

Cet équipement dépend des installations du bâtiment pour la protection de surintensité. Assurez-vous de ne pas utiliser un fusible ou un disjoncteur de plus de 120 Vca, 15 A U.S. (240 Vca, 16 A internationaux) sur les conducteurs de phase.

**⚠ Caution:**

Avertissement: Le périphérique est un produit de Classe A. Dans un environnement domestique, ce périphérique est susceptible de provoquer des interférences radio, auquel cas l'utilisateur doit prendre les mesures appropriées.

**⚠ Caution:**

Avertissement: Si vous montez cet appareil en rack, ne superposez pas les unités directement les unes sur les autres dans le rack. Chaque unité doit être fixée au rack à l'aide des supports de montage appropriés. Les supports de montage ne sont pas conçus pour supporter plusieurs unités.

**⚠ Voltage:**

Utilisez uniquement des cordons d'alimentation possédant un conducteur de terre. S'il n'y a pas de conducteur de terre, une personne qui touche le commutateur peut recevoir un choc électrique. L'absence de conducteur de terre au commutateur peut provoquer des émissions excessives.

**⚠ Warning:**

Avertissement: La seule manière de couper l'alimentation de l'appareil est de déconnecter le cordon d'alimentation. Connectez toujours le cordon d'alimentation à un endroit accessible rapidement et en toute sécurité en cas d'urgence.

**⚠ Warning:**

Avertissement: L'équipement de fibres optiques peut émettre une lumière laser ou infrarouge nuisible à vos yeux. Ne regardez jamais en direction de fibres optiques ou d'un port connecteur. Supposez toujours que les câbles de fibres optiques sont connectés à une source de lumière.

**⚠ Caution:**

Avertissement: Risque d'explosion si la batterie est remplacée par un type incorrect. Débarassez-vous des batteries utilisées selon les instructions.



# Chapter 6: Português

---

## Antes de você comece

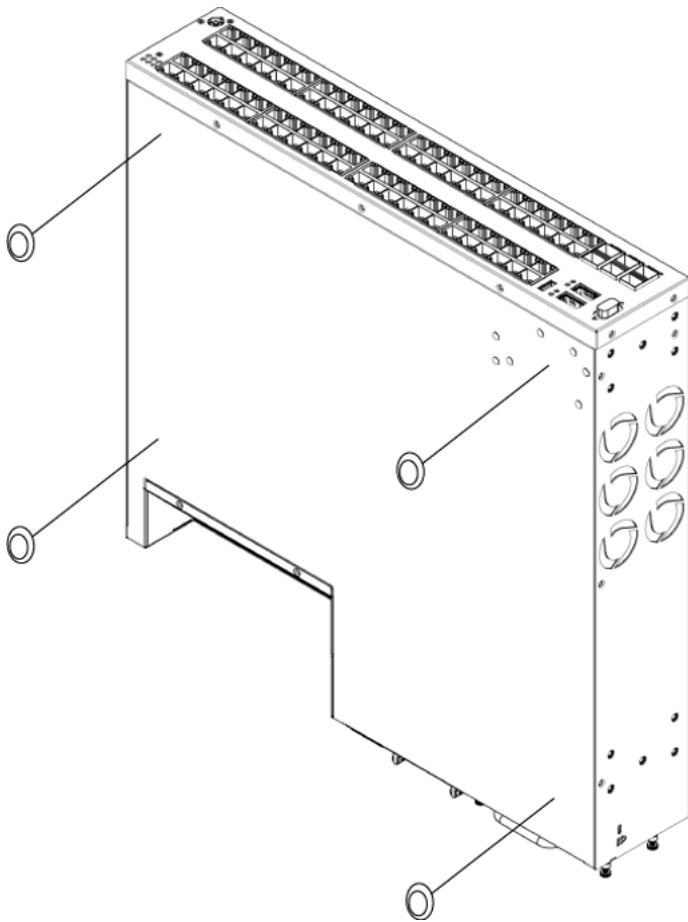
Assegure a área onde você instala e usa a série de Avaya ERS 5600 Series comuta reuniões as seguintes exigências ambientais:

- Temperatura ambiental entre 32° e 106° F (0° e 50° C)
- Umidade relativa entre 10% e 90% noncondensing
- Nenhuma fonte de calor próximas tais como respiradouros de ar quente ou a luz solar direta
- Nenhuma fonte próximas do ruído eletromagnético severo
- Nenhuma poeira excessiva
- Fonte de poder adequado dentro de seis pés (1,8 medidor); um circuito requerido para cada fonte de alimentação (veja especificações da tabela, da alimentação de DC da C. A. e)
- Pelo menos 2 polegadas (5,08 cm) em cada lado da unidade do interruptor para a ventilação
- Espaço adequado no dianteiro e traseiro do interruptor para o acesso aos cabos

---

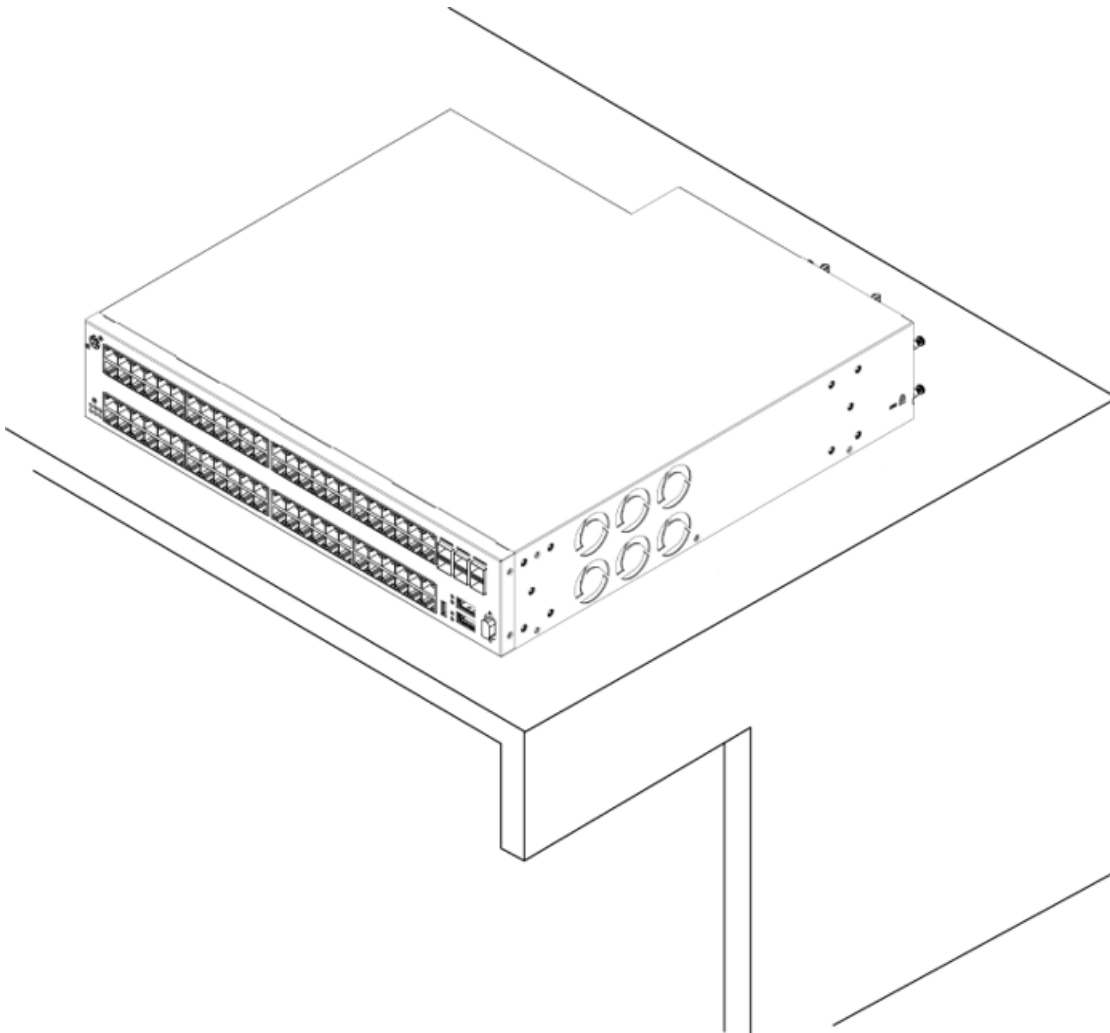
## Instalando o ERS 5600 Series em uma tabela ou em uma prateleira

Você pode instalar um único Ethernet Routing Switch em toda a superfície plana que puder com segurança suportar o peso do ERS 5600 Series e dos cabos unidos (21 a 33 libras ou 9,5 a 15 quilogramas). La figura fornece instruções em instalar o ERS 5600 Series em uma tabela ou em uma prateleira.



**Figure 12: Instalando o ERS 5600 Series na tabela ou na prateleira**

Una os pés de borracha nas posições marcadas.



Ajuste o ERS 5600 Series em uma tabela ou prateleira.

**\* Note:**

Reserve pelo menos 2 polegadas (5,1 cm) em cada lado para a ventilação apropriada e pelo menos 5 polegadas (12,7 cm) na parte traseira para o afastamento do cabo de poder.

---

## Instalando o ERS 5600 Series em uma cremalheira de equipamento

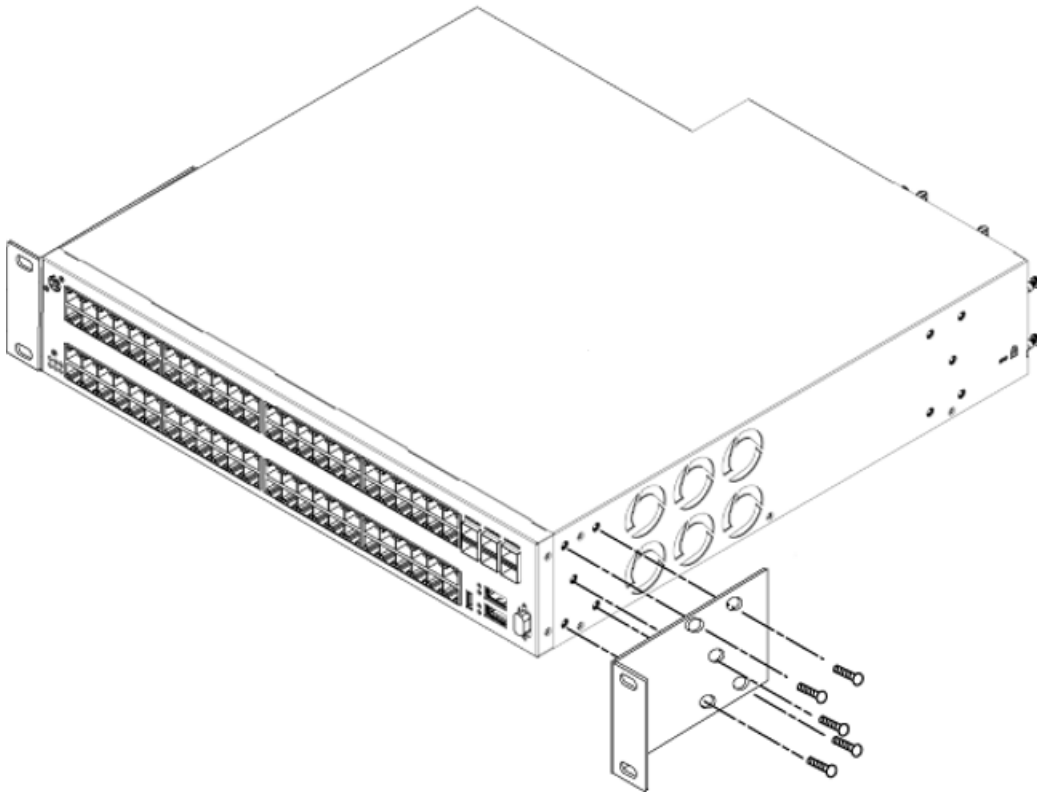
Ferramenta requerida: Chave de fenda Phillips para unir os suportes ao B

Exigências da cremalheira:

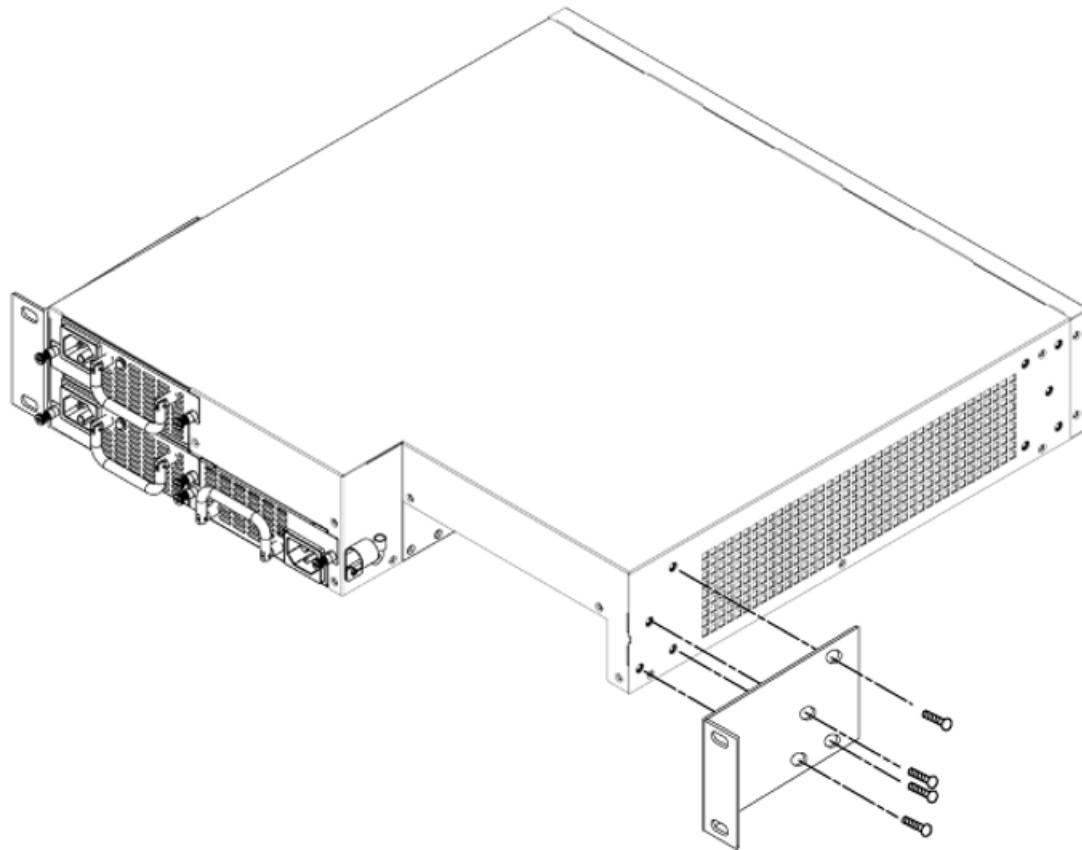
- Um espaço de 2,8 polegadas é requerido para cada interruptor em um padrão de EIA ou de IEC cremalheira de equipamento de 19 polegadas (48,2-centimeter).
- Aproprie o espaço para acomodar a altura da unidade:
  - Os modelos de ERS 5650 requerem uma unidade da cremalheira (1,75 polegada, 44,45 milímetros)
  - Os modelos de ERS 5632 requerem 1,5 unidade da cremalheira (2,625 polegadas, 66,68 milímetros)
  - Os modelos de ERS 5698 requerem 2 unidades da cremalheira (3,5 polegadas, 88,90 milímetros)
- A cremalheira deve ser aparafusada ao assoalho e ser apoiada, se necessário.
- A cremalheira deve ser aterrada ao mesmo elétrodo aterrando usado pelo serviço de poder na área. O trajeto à terra deve ser permanente e não deve exceder 1 ohm da resistência da cremalheira ao elétrodo aterrando.

Da figura fornece instruções em instalar o ERS 5600 Series em uma cremalheira.

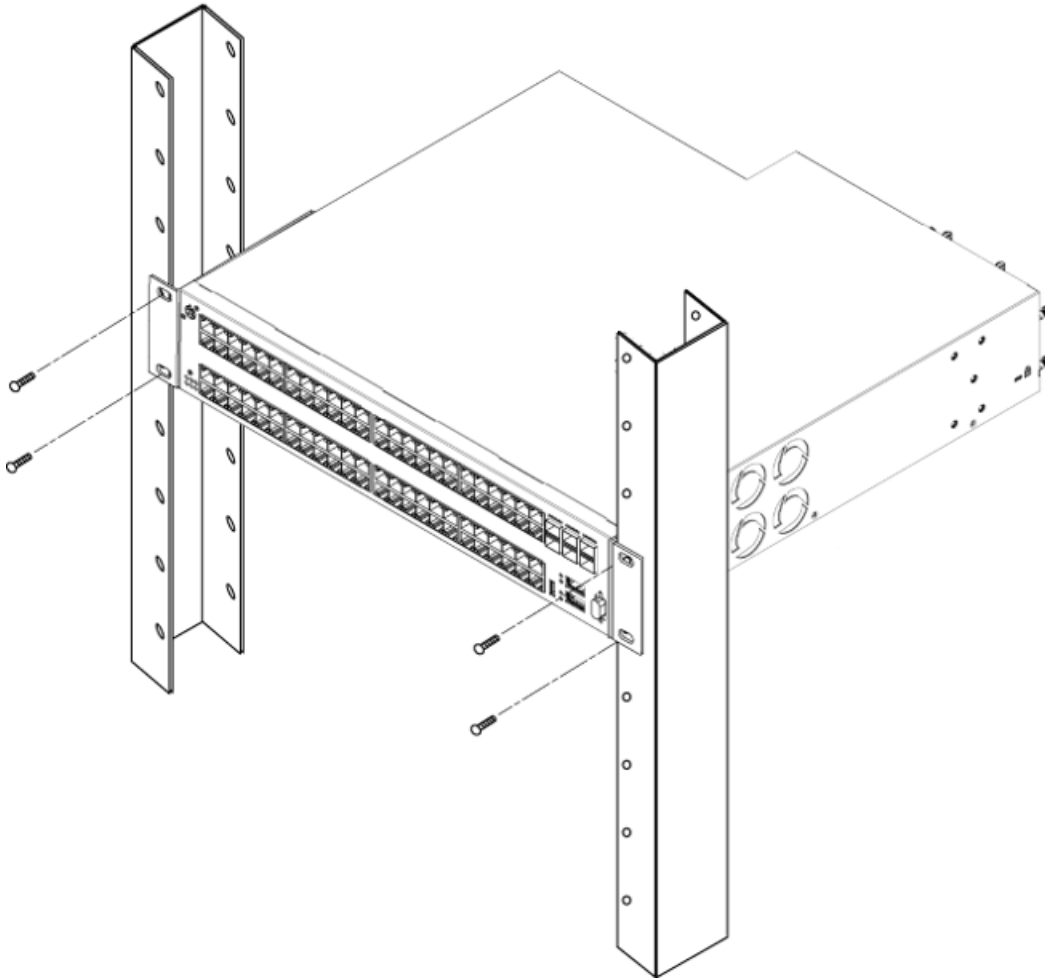


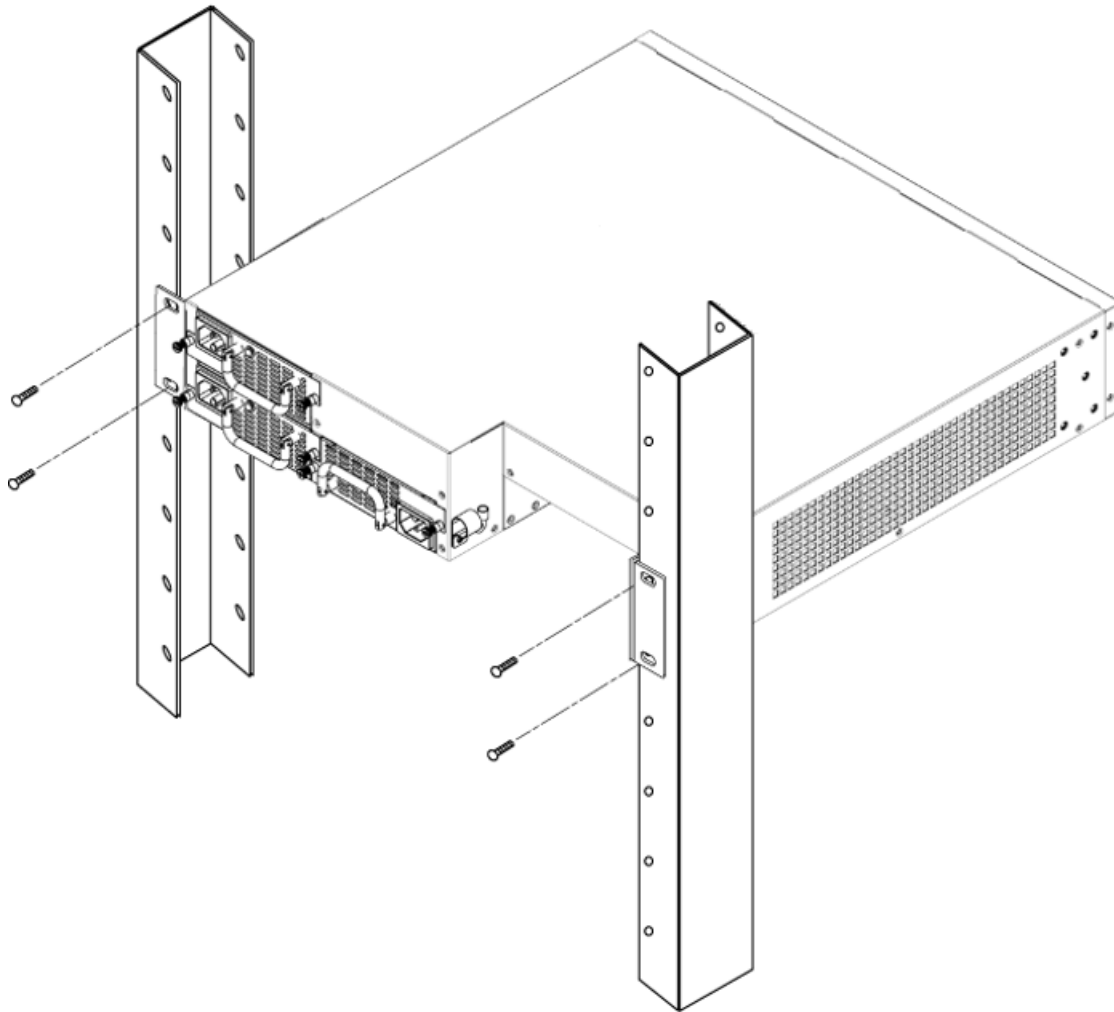


**Figure 13: Instalando ERS 5600 Series em uma cremalheira**



Una um suporte a cada lado do ERS 5600 Series.





Deslize o ERS 5600 Series na cremalheira. Introduza e aperte cremalheira-montam os parafusos.

---

## Especificações do poder

---

## Especificações da alimentação de DC da C. A. e

A seguinte tabela descreve especificações da alimentação de DC da C. A. e Para o ERS 5600 séries.

**Table 8: Especificações do poder: série do Ethernet Routing Switch 5600 Series**

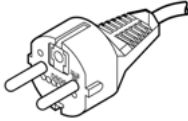
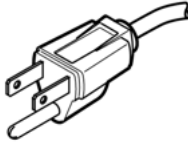
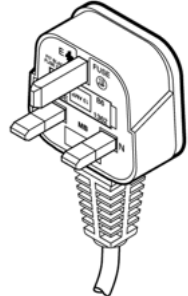
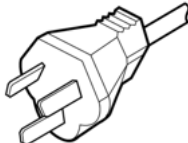
Modelo	Corrente da entrada Ampères máximos por a fonte de alimentação			Consumo de potência	Avaliação térmica	A fonte de alimentação usou-se	Ethernet excedente do poder (PoE)
	100- 120 VAC	48 VDC	200-240 VAC	Maximo W	Btu/h maximo	Watts AC/ DC, DC/ DC	Poder por o porto (watts)
ERS 5632FD	1,8		0,9	190	650	300	n/a
ERS 5632FD DC		4,2		190	650	300	n/a
ERS 5650TD	1,2		0,6	132	450	300	n/a
ERS 5650TD DC		3,0	0,6	132	450	300	n/a
ERS 5650TD-PWR	5,5		2,75	218	745	600	8.0
ERS 5650TD-PWR DC	10,5		5,25	290	990	1000	15,4
ERS 5650 TD-PWR (2 fontes de alimentação)	5,3 *		2,65 *	290	990	600 *	15,4
ERS 5650 TD-PWR DC		21		290	990	1000	15,4
ERS 5698TF D	2,0		1,,0	215	735	300	n/a
ERS 5698TF D DC		4,5		215	735	300	n/a

Modelo	Corrente da entrada Ampères máximos por a fonte de alimentação			Consumo de potência	Avaliação térmica	A fonte de alimentação usou-se	Ethernet excedente do poder (PoE)
	100- 120 VAC	48 VDC	200-240 VAC	Maximo W	Btu/h maximo	Watts AC/ DC, DC/ DC	Poder por o porto (watts)
ERS 5698TF D-PWR	10,5		5,25	400	1365	1000	8
ERS 5698TF D-PWR (2 fontes de alimentação)	9,5 *		4,75 *	545	1850	1000 *	15,4
ERS 5698TF D-PWR DC		26		400	1365	1000	8
ERS 5698TF D-PWR DC (2 fontes de alimentação)		21 *		545	1850	1000 *	15,4
* por a fonte de alimentação							

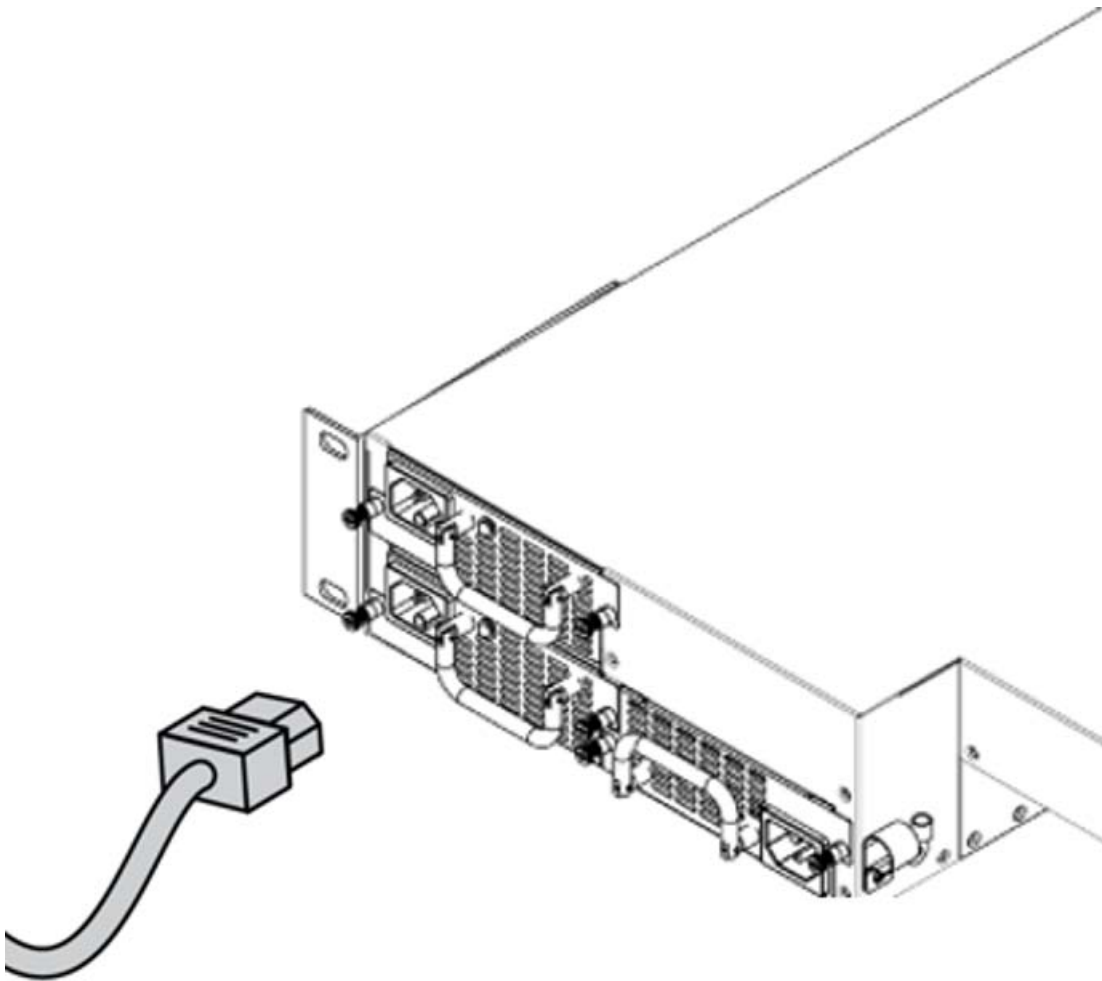
## Poder de C.A. conectando

Cabo requerido: Cabo de poder da C.A. que se encontra com as exigências de seu código elétrico local. Consulte à tabela para especificações do plugue.

**Table 9: Especificações internacionais do cabo de poder**

Descrição do país/plugue	Especificações	Plugue típico
Europa continental: <ul style="list-style-type: none"> <li>• CEE7 plugue do macho do padrão VII</li> <li>• Cabo Harmonized (marking de HAR na parte externa do revestimento do cabo a comply com o original Harmonized CENELEC HD-21)</li> </ul>	220 ou 230 Vca 50Hz Fase monofásica	 <p style="text-align: right;">228FA</p>
ESTADOS UNIDOS/Canadá/Japão: <ul style="list-style-type: none"> <li>• Plugue do macho de NEMA5-15P</li> <li>• UL-reconhecido (UL carimbados no revestimento do cabo)</li> <li>• CSA-certificado (etiqueta de CSA fixada ao cabo)</li> </ul>	100 ou 120 Vca 50-60 Hz Fase monofásica	 <p style="text-align: right;">227FA</p>
Reino Unido: <ul style="list-style-type: none"> <li>• Plugue BS1363 masculino com fusível</li> <li>• Cabo Harmonized</li> </ul>	240 Vca 50 Hz Fase monofásica	 <p style="text-align: right;">229FA</p>
Australia: AS3112-1981 plugue masculino	240 Vca 50 Hz Fase monofásica	 <p style="text-align: right;">230FA</p>

A série de ERS 5600 Series não tem um interruptor de poder. Quando você conectar o cabo de poder da C.A. a uma tomada de poder apropriada da C.A., os poderes de ERS 5600 Series acima imediatamente. Da figura mostra como conectar o cabo de poder da C.A. à série de ERS 5600 Series.



**Figure 14: Conectando o cabo de poder da C.A. à série de ERS 5600 Series**

Conecte o cabo de poder da C.A. à parte traseira do ERS 5600 Series, e conecte então o cabo a uma tomada de poder.

---

## Mensagens de segurança

 **Warning:**

Aviso: A instalação deve ser executada pelo pessoal de serviço qualificado somente. Leia e siga todas as observações de advertência e instruções marcadas no produto ou incluídas na documentação.



 **Danger:**

Perigo: Este equipamento confia na instalação do edifício para a proteção da sobrecarga. Assegure-se de que um disjuntor do fusível ou de circuito não maior de 120 VAC, 15 UNS ESTADOS UNIDOS (240 VAC, 16 um internacional) esteja usado nos condutores da fase.

 **Caution:**

Cuidado: Este dispositivo é um produto da classe A. Em um ambiente doméstico, este dispositivo pode causar a interferência de rádio, que no caso o usuário pode ser requerido fazer exame de medidas apropriadas.

 **Caution:**

Cuidado: Ao montar este dispositivo em uma cremalheira, não empilhe unidades diretamente no alto de um outro na cremalheira. Cada unidade deve ser fixada à cremalheira com os suportes de montagem apropriados. Os suportes de montagem não são projetados suportar unidades múltiplas.

 **Voltage:**

Perigo: Use somente os cabos de poder que têm um trajeto aterrando. Sem uma terra apropriada, uma pessoa que toque o interruptor está no perigo de receber um choque elétrico. A falta de um trajeto aterrando ao interruptor pode resultar em emissões excessivas.

 **Warning:**

Aviso: Desconectar o cabo de poder é a única maneira desligar o poder para este dispositivo. Conecte sempre o cabo de poder em uma posição que possa ser alcançada rapidamente e com segurança em caso de uma emergência.

 **Warning:**

Aviso: O equipamento ótico da fibra pode emitir-se o laser ou a luz infravermelha que podem ferir seus olhos. Nunca olhe em um porto de fibra óptica ou do conector. Suponha sempre que os cabos óticos da fibra estão conectados a uma fonte clara.

 **Caution:**

Cuidado: Risco da explosão se a bateria for substituída por um tipo incorreto. Disponha de baterias usadas de acordo com as instruções.



